

Communicative rotary actuator for ball valves

- Torque motor 10 Nm
- Nominal voltage AC/DC 24 V
- Control communicative
- Communication via KNX (S-Mode)
- Conversion of sensor signals
- Integrated KNX 6-way valve application
- KNX condensation monitoring
- PWIS/LABS-compliant according to VDMA 24364



## Technical data

<b>Electrical data</b>	Nominal voltage	AC/DC 24 V
	Nominal voltage frequency	50/60 Hz
	Nominal voltage range	AC 19.2...28.8 V / DC 21.6...28.8 V
	Power consumption in operation	3.5 W
	Power consumption in rest position	1.2 W
	Power consumption for wire sizing	6 VA
	Connection supply / control	Cable 1 m, 6x 0.75 mm <sup>2</sup>
<b>Data bus communication</b>	Communicative control	KNX (S-Mode)
	Number of nodes	max. 64 per line segment, reduce number of nodes with connecting cable with short lines
	Communication medium	KNX TP
	Configuration mode	S-Mode
	Current consumption of KNX-Bus	max. 5 mA
<b>Functional data</b>	Torque motor	10 Nm
	Position accuracy	±5%
	Manual override	with push-button, can be locked
	Running time motor	90 s / 90°
	Running time motor variable	45...170 s
	Sound power level, motor	45 dB(A)
	Adaptation setting range	manual (automatic on first power-up)
	Adaptation setting range variable	No action Adaptation when switched on Adaptation after pushing the manual override button
	Override control, controllable via bus communication	MAX (maximum position) = 100% MIN (minimum position) = 0% ZS (intermediate position) = 50%
	Override control variable	MAX = (MIN + 33%)...100% MIN = 0%...(MAX - 33%) ZS = MIN...MAX
	Parametrisation	with service tool ZTH EU Fast addressing 1...16 via push button possible
Position indication	Mechanical, pluggable	
<b>Safety data</b>	Protection class IEC/EN	III, Safety Extra-Low Voltage (SELV)
	Degree of protection IEC/EN	IP54
	EMC	CE according to 2014/30/EU

**Technical data**

<b>Safety data</b>	Certification IEC/EN	IEC/EN 60730-1 and IEC/EN 60730-2-14
	PWIS/LABS-conformity	According to VDMA 24364 (test class C1) Approved for use in zone II Cleaning with low-pressure plasma treatment
	Type of action	Type 1
	Rated impulse voltage supply / control	0.8 kV
	Pollution degree	3
	Ambient humidity	Max. 95% RH, non-condensing
	Ambient temperature	0...50°C [32...122°F]
	Storage temperature	-10...40°C [14...104°F]
	Servicing	maintenance-free
	<b>Weight</b>	Weight

**Safety notes**

- This device has been designed for use in stationary heating, ventilation and air-conditioning systems and must not be used outside the specified field of application, especially in aircraft or in any other airborne means of transport.
- Outdoor application: only possible in case that no (sea) water, snow, ice, insolation or aggressive gases interfere directly with the device and that it is ensured that the ambient conditions remain within the thresholds according to the data sheet at any time.
- Only authorised specialists may carry out installation. All applicable legal or institutional installation regulations must be complied with during installation.
- The switch for changing the direction of rotation may only be operated by authorised specialists. The direction of rotation must not in particular be reversed in a frost protection circuit.
- The device may only be opened at the manufacturer's site. It does not contain any parts that can be replaced or repaired by the user.
- Cables must not be removed from the device.
- The device contains electrical and electronic components and must not be disposed of as household refuse. All locally valid regulations and requirements must be observed.
- PWIS/LABS-conformity is guaranteed as long as the packaging is unopened. Once the PWIS/LABS-compliant packaging has been opened, the proper handling of the products is the responsibility of the customer. PWIS/LABS-conformity of unopened products is guaranteed for a period of one year after cleaning, provided they are handled properly, professionally and cleanly. Proof of proper, professional and clean handling is the responsibility of the purchaser. Ensure that the required cleanliness of the products is maintained. Do not touch the products with bare hands. Belimo accepts no liability for the consequences resulting from the contamination of a product caused by the customer.

**Product features**

- Operating mode** The actuator is equipped with an integrated interface for KNX (S-Mode) and can be connected with all KNX devices that have corresponding data points available.  
The KNX application allows the use of the valve actuator with 2- and 3-way valves with one setpoint as well as with 6-way valves in 4-pipe systems with 2 setpoints for heating and cooling.
- Converter for sensors** Connection option for a sensor (passive or active sensor or switching contact). In this way, the analogue sensor signal can be easily digitised and passed along to KNX.

## Product features

**Application** The 6-way application parametrisable in the KNX actuator allows 4-pipe systems to be controlled using 2 separate setpoints for the heating and cooling sequences.  
 Heating sequence setpoint 0...100% corresponds to 67...100% valve position.  
 Cooling sequence setpoint 0...100% corresponds to 33...0% valve position.  
 If no sequence is active or the condensation monitor has been triggered, the actuator moves to the closed position (middle position 50%).

When operating with the 6-way application, the factory settings for the Min and Max settings (Min=0%, Max=100%) are recommended. The parametrisation of the Min and Max values must be selected carefully when the 6-way application is active, as they affect the control ranges of the heating and cooling sequence.

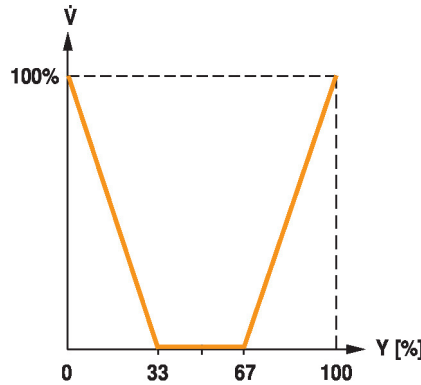

- Parametrisable actuators** The factory settings cover the most common applications. As desired, individual parameters can be adapted for specific systems or servicing with a service tool (e.g. ZTH EU) or the ETS planning and commissioning tool.
- Simple direct mounting** Straightforward direct mounting on the ball valve with only one central screw. The assembly tool is integrated in the plug-in position indication. The mounting orientation in relation to the ball valve can be selected in 90° steps.
- Manual override** Manual override with push-button possible (the gear train is disengaged for as long as the button is pressed or remains locked).
- Adjustable angle of rotation** Adjustable angle of rotation with mechanical end stops.
- Home position** The first time the supply voltage is switched on, i.e. at the time of commissioning, the actuator carries out an adaptation, which is when the operating range and position feedback adjust themselves to the mechanical setting range.  
 The actuator then moves into the position defined by the control signal.  
 Factory setting: Y2 (counter-clockwise rotation).
- Adaptation and synchronisation** An adaptation can be triggered manually by pressing the "Adaptation" button or with the PC-Tool. Both mechanical end stops are detected during the adaptation (entire setting range).  
 Automatic synchronisation after pressing the manual override button is configured. The synchronisation is in the home position (0%).  
 The actuator then moves into the position defined by the control signal.  
 A range of settings can be adapted using the PC-Tool (see MFT-P documentation)
- Condensation monitoring** By using a condensation monitor at the sensor input of the actuator and the condensation monitoring activated in the KNX application, the formation of condensation water during the cooling sequence can be prevented.
- Behaviour with 2-way and 3-way application (factory setting):  
 When the condensation monitoring is active, the actuator closes (0%).
- Behaviour with active 6-way application (4-pipe system):  
 When the condensation monitoring is active, the actuator moves to the middle position (50%).

## Accessories

Tools	Description	Type
	Service tool, with ZIP-USB function, for parametrisable and communicative Belimo actuators, VAV controller and HVAC performance devices	ZTH EU
	Belimo PC-Tool, Software for adjustments and diagnostics	MFT-P
	Adapter for Service-Tool ZTH	MFT-C
	Connecting cable 5 m, A: RJ11 6/4 ZTH EU, B: 6-pin for connection to service socket	ZK1-GEN
	Connecting cable 5 m, A: RJ11 6/4 ZTH EU, B: free wire end for connection to MP/PP terminal	ZK2-GEN

## Electrical installation



Supply from isolating transformer.

Parallel connection of other actuators possible. Observe the performance data.

Direction of rotation switch is covered. Factory setting: Direction of rotation Y2.

**Wire colours:**

- 1 = black
- 2 = red
- 3 = white
- 5 = orange
- 6 = pink
- 7 = grey

**Functions:**

- D+ = KNX+ (pink > red)
  - D- = KNX- (grey > black)
- The connection to the KNX line should take place via WAGO connecting terminals 222/221.

**Wiring diagrams**

Connection without sensor

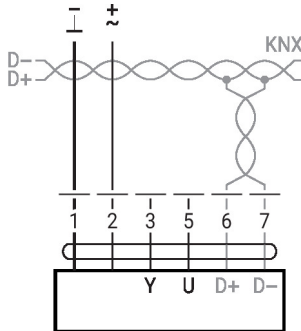

Connection with passive sensor, e.g. Pt1000, Ni1000, NTC

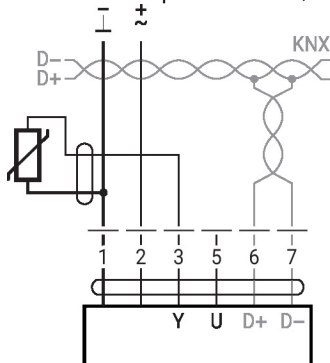

Ni1000	-28...+98°C	850...1600 Ω <sup>2)</sup>
PT1000	-35...+155°C	850...1600 Ω <sup>2)</sup>
NTC	-10...+160°C <sup>1)</sup>	200 Ω...60 kΩ <sup>2)</sup>

1) depending on type

2) Resolution 1 Ohm

Compensation of the measured value is recommended

## Electrical installation

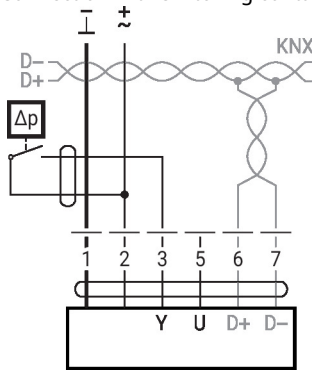
 Connection with switching contact, e.g.  $\Delta p$  monitor switch

Switching contact requirements:  
The switching contact must be able to switch a current of 16 mA at 24 V accurately.

Connection with active sensor, e.g. 0...10 V @ 0...50°C

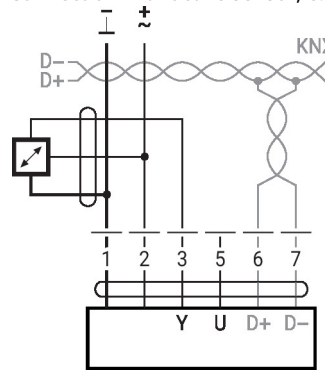

Possible voltage range: 0...32 V  
Resolution 30 mV

- Switching current 16 mA @ 24 V
- Start point of the operating range must be parametrised on the KNX actuator as  $\geq 0.5$  V

## KNX group objects

Name	Type	Flags					Data point type				Values range
		C	R	W	T	U	ID	DPT_Name	Format	Unit	
Setpoint	I	C	-	W	-	-	5.001	_percentage	1 Byte	%	[0...100] Resolution 0.4%
Setpoint Heating	I	C	-	W	T	-	5.001	_percentage	1 Byte	%	[0...100] Resolution 0.4%
Setpoint Cooling	I	C	-	W	-	-	5.001	_percentage	1 Byte	%	[0...100] Resolution 0.4%
Override control	I	C	-	W	-	-	20.*	_enum	1 Byte	-	0 = no override 1 = Open 2 = Closed 3 = Min 4 = Mid 5 = Max
Reset	I	C	-	W	-	-	1.015	_reset	1 Bit	-	0 = no action 1 = reset
Adaptation	I	C	-	W	-	-	1.017	_switch	1 Bit	-	0 = no action 1 = adapt
Testrun	I	C	-	W	-	-	1.017	_switch	1 Bit	-	0 = no action 1 = Testrun
Min	I/O	C	R	W	-	-	5.001	_percentage	1 Byte	%	[0...100] Resolution 0.4%
Max	I/O	C	R	W	-	-	5.001	_percentage	1 Byte	%	[0...100] Resolution 0.4%
Relative position	O	C	R	-	T	-	5.001	_percentage	1 Byte	%	[0...100] Resolution 0.4%
Absolute position	O	C	R	-	T	-	8.011 7.011	_rotation_angle _length	2 Byte	° mm	[-32'768...32'768] [0...65'535]
Fault state	O	C	R	-	T	-	1.002	_boolean	1 Bit	-	0 = no fault 1 = fault
Overridden	O	C	R	-	T	-	1.002	_boolean	1 Bit	-	0 = not active 1 = active
Gear disengagement active	O	C	R	-	T	-	1.002	_boolean	1 Bit	-	0 = engaged 1 = disengaged
Service information	O	C	R	-	T	-	22.*	_bitset16	2 Byte	-	Bit 0 (1) Excessive utilisation Bit 1 (2) Mechanical travel increased Bit 2 (4) Mechanical overload Bit 3 (8) - (Not used) Bit 4 (16) - (Not used) Bit 5 (32) - (Not used) Bit 6 (64) - (Not used) Bit 7 (128) - (Not used) Bit 8 (256) Internal activity Bit 9 (512) Bus watchdog triggered
Sensor value - Resistance R - Temperature - Relative Humidity - Air Quality - Voltage mV - Voltage scaled - Voltage scaled % - Switch - Dewpoint control	O	C	R	-	T	-	14.060 9.001 9.007 9.008 9.020 7.* 5.001 1.001 1.001	_resistance _temperature _humidity _parts/million _voltage _pulses_length _percentage _switch _switch	4 Byte 2 Byte 2 Byte 2 Byte 2 Byte 2 Byte 1 Byte - -	Ω °C % RH ppm mV mm % - -	- [-273...670'760] [0...670'760] [0...670'760] [-670'760...670'760] [0...65'535] [0...100] 0/1 0/1

## KNX group objects (continuation)

<b>Setpoint</b>	Specification of actuator position in % between the parameterised Min and Max limits. Recommended for 2-way and 3-way ball valves.
<b>Setpoint Heating</b>	Specification of the valve position for the heating sequence of a 6-way ball valve. The heating setpoint can be specified in the range from 0...100%. The flow can be limited with the Max communication object. The setpoint object (heating/cooling) with the last command is preferred.
<b>Setpoint Cooling</b>	Specification of the valve position for the cooling sequence of a 6-way ball valve. The cooling setpoint can be specified in the range from 0...100%. The flow can be limited with the Min communication object. The setpoint object (heating/cooling) with the last command is preferred.
<b>Override control</b>	Overriding the setpoint with defined override states. As data point type, 1 Byte (unsigned) is recommended (DPT 20.*)
<b>Reset</b>	Resetting the stored service messages (see KNX group object <i>Service information</i> ).
<b>Adaptation</b>	Perform the adaptation. An active adaptation is signaled in Bit 8 of <i>Service information</i> .
<b>Testrun</b>	Performance of a testrun that checks the entire operating range. An active adaptation is signaled in Bit 8 of <i>Service information</i> . After completion, detected faults (mechanical overload, mechanical travel increased) are signaled in <i>Service information</i> .
<b>Min</b>	Minimum Limit (position) in %. Caution: Changing the setting may result in malfunctions.
<b>Max</b>	Maximum Limit (position) in %. Caution: Changing the setting may result in malfunctions.
<b>Relative position</b>	Current actuator position in %
<b>Absolute position</b>	Absolute position/stroke The data point type is to be selected depending on the type of movement: [°]      DPT 8.011 [mm]     DPT 7.011
<b>Fault state</b>	Collective fault based on Bit 0...Bit 7 of <i>Service information</i> .
<b>Overridden</b>	Signaling of an active override control (OPEN/CLOSED) The device can be commanded via the KNX group object <i>Override control</i> or via the forced switching at the input Y/3. Only the override controls OPEN and CLOSED are signaled.
<b>Gear disengagement active</b>	Signaling an active gear disengagement
<b>Service information</b>	Detailed information regarding device status As data point type, Bitset 16-Bit is recommended (DPT 22.*) Status information: Bit 0:    Motor operation in relation to operating period too high Bit 1:    Mechanical travel increased, e.g. defined end position exceeded Bit 2:    Mechanical overload, i.e. defined end position not reached Bit 3...7: not used with this device type Bit 8:    Internal activity (Synchronisation, Adaptation, Testrun, ...) Bit 9:    Bus watchdog triggered Bit 0:    Bit 7 are stored by the device and can be reset with the KNX group object <i>Reset</i> . As an alternative, the several bits can be read as collective fault state.
<b>Sensor value</b>	The representation of the sensor value is dependent on the parameterization. See section „KNX parameters – Sensor“





## KNX parameters

**Sensor**

**Sensor type** The input Y/3 can be used to connect a sensor. The sensor value is digitised and made available as KNX communication object.

Values range: No sensor  
 Active sensor (0...32 V)  
 Passive sensor 1K  
 Passive sensor 20K  
 Switch (0 / 1)  
 Temperature sensor PT1000 / Ni1000 / NTG10K  
 Humidity sensor (0...10 V corresponds 0...100%)  
 Air quality sensor CO2 (0...10 V corresponds 0...2'000 ppm)  
 Condensation monitor (0 / 1)

Factory setting: No sensor

A switching to Y/3 is treated as local override in the absence of sensor parameterization.

**Increment for sensor value update** The sensor value is transferred at the time of a value change insofar as this changes by the parameterised difference value.

Values range: 0...65'535 (0.5...10 at temperature)

Factory setting: 1

The transfer is deactivated with 0 in the event of a value change. Without value change, the sensor value is sent because of the repetition time.

**Output**  
 (for sensor type „Active sensor“)

Only for „Active sensor“ sensor type

Values range: Sensor value mV (DPT 9.020)  
 Sensor value scaled (DPT 7.xxx)  
 Sensor value scaled % (DPT 5.001)

Factory setting: -

For „Sensor value mV“, the measured voltage is made available without processing. In the case of the scaled sensor values, a linear transformation can be defined with two points.

**Polarity**  
 (for sensor type „Switch“)

The polarity can be defined for the sensor types „Switch“ and „Dewpoint control“.

Values range: Normal  
 Inverted

Factory setting: -

## KNX workflows

**Product database** The product database for the import in ETS4 or higher is available at the Belimo website.

**Setting physical address** The programming of the physical address takes place by ETS and the programming button on the device.

If the programming button is not accessible or accessible only with difficulty, then the address can be set using a point-to-point connection: "Overwrite Individual Address: 15.15.255"

As a third possibility, the physical address can be programmed on the basis of the KNX series number (e.g. with Moov'n'Group). The KNX series number is placed on the device in two versions. One sticker can be removed for adhesion on the commissioning journal, for example.

**Firmware upgrade** The KNX firmware of the device is updated automatically with the programming of the application program if the product database has a more recent version.

The first programming procedure takes somewhat longer in such cases (>1 min).

**Resetting to KNX factory settings** If necessary, the device can be reset manually to the KNX factory settings (physical address, group address, KNX parameters).

For the reset, the programming button on the device must be pressed down for at least 5 s during start-up.

## Operating controls and indicators

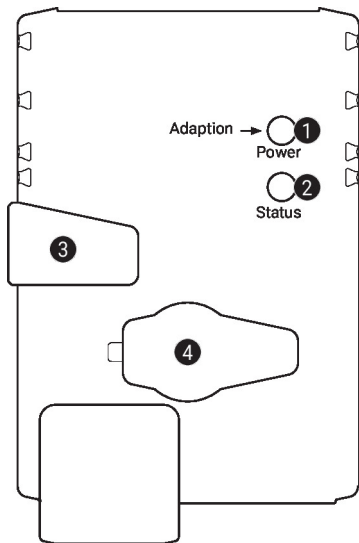
**1 Push-button and LED display green**

Off: No power supply or malfunction

On: In operation

Press button: Triggers angle of rotation adaptation, followed by standard mode

**2 Push-button and LED display yellow**

Off: The actuator is ready

On: Adaptation or synchronisation process active or actuator in programming mode (KNX)

Flashing: Connection test (KNX) active

Press: In operation (>3 s): Switch the programming mode on and off (KNX)

button: When starting (>5 s): Reset to factory setting (KNX)

**3 Manual override button**

Press button: Gear train disengages, motor stops, manual override possible

Release button: Gear train engages, standard mode

**4 Service plug**

For connecting parametrisation and service tools

## Service



Notes

The actuator can be configured by PC-Tool and ZTH EU via the service socket.

**Tool connection**

The actuator can be parametrised by ZTH EU via the service socket.  
For an extended parametrisation the PC tool can be connected.

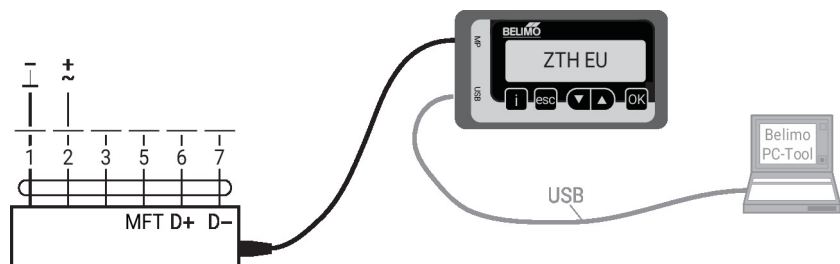

## Dimensions

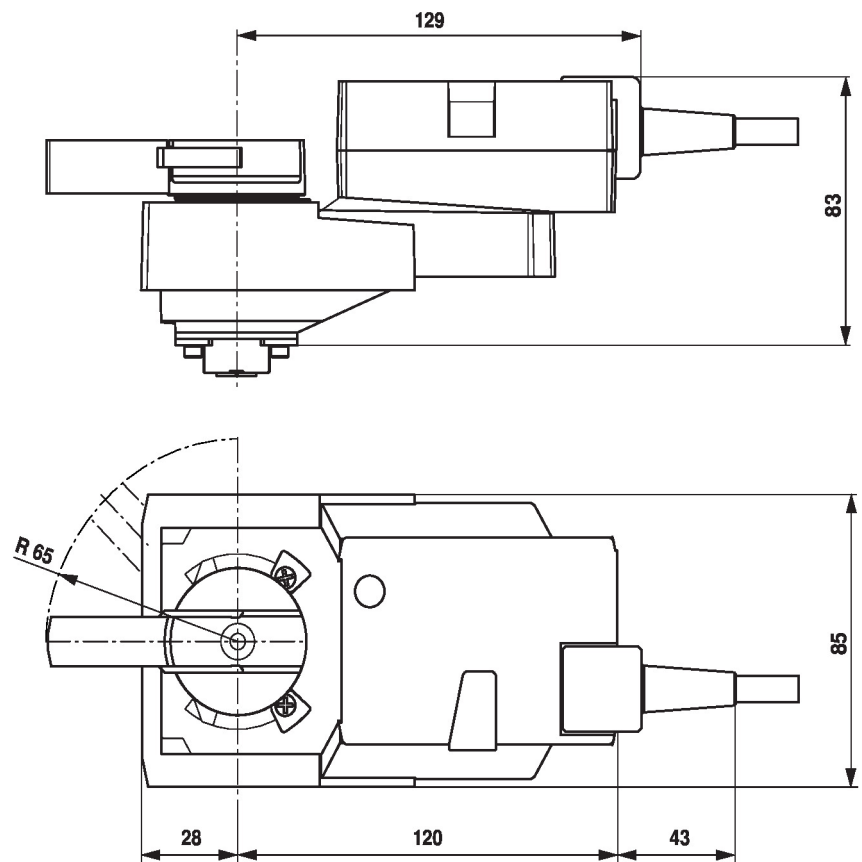

## Further documentation

- Tool connections
- The complete product range for water applications
- Data sheets for ball valves
- Installation instructions for actuators and/or ball valves
- General notes for project planning