

Communicative rotary actuator fail-safe for adjusting dampers in technical building installations

- Air damper size up to approx. 2 m²
- Torque motor 10 Nm
- Nominal voltage AC/DC 24 V
- Control modulating, communicative 2...10 V variable
- Position feedback 2...10 V variable
- Communication via Belimo MP-Bus
- Conversion of sensor signals
- Optimum weather protection for use outdoors (for use in ambient temperatures up to -40°C, there is a separate actuator available with built-in heater)



Technical data

Electrical data	Nominal voltage	AC/DC 24 V
	Nominal voltage frequency	50/60 Hz
	Nominal voltage range	AC 19.2...28.8 V / DC 21.6...28.8 V
	Power consumption in operation	5.5 W
	Power consumption in rest position	3.5 W
	Power consumption for wire sizing	8 VA
	Connection supply / control	Cable 1 m, 4x 0.75 mm ² (halogen-free)
	Parallel operation	Yes (note the performance data)
Data bus communication	Communicative control	MP-Bus
	Number of nodes	MP-Bus max. 8
Functional data	Torque motor	10 Nm
	Torque fail-safe	10 Nm
	Operating range Y	2...10 V
	Input impedance	100 kΩ
	Operating range Y variable	Start point 0.5...30 V End point 2.5...32 V
	Operating modes optional	Open/close 3-point (AC only) Modulating (DC 0...32 V)
	Position feedback U	2...10 V
	Position feedback U note	Max. 0.5 mA
	Position feedback U variable	Start point 0.5...8 V End point 2.5...10 V
	Position accuracy	±5%
	Direction of motion motor	selectable with switch L/R
	Direction of motion variable	electronically reversible
	Direction of motion fail-safe	L (ccw)
	Direction of motion note	Y = 0 V: At switch position 0 (ccw rotation) / 1 (cw rotation)
	Manual override	by means of hand crank and locking switch
	Angle of rotation	Max. 95°
Angle of rotation note	adjustable starting at 33% in 2.5% steps (with mechanical end stop)	
Running time motor	150 s / 90°	

Technical data

Functional data	Running time motor variable	40...150 s	
	Running time fail-safe	<20 s @ -20...50°C / <60 s @ -30°C	
	Sound power level, motor	40 dB(A)	
	Adaptation setting range	manual	
	Adaptation setting range variable	No action Adaptation when switched on Adaptation after using the hand crank	
	Override control	MAX (maximum position) = 100% MIN (minimum position) = 0% ZS (intermediate position, AC only) = 50%	
	Override control variable	MAX = (MIN + 32%)...100% MIN = 0%...(MAX - 32%) ZS = MIN...MAX	
	Mechanical interface	Universal shaft clamp 12...26.7 mm	
	Position indication	Mechanical, pluggable	
	Service life	Min. 60'000 fail-safe positions	
	Safety data	Protection class IEC/EN	III, Safety Extra-Low Voltage (SELV)
		Power source UL	Class 2 Supply
		Degree of protection IEC/EN	IP66/67
Degree of protection NEMA/UL		NEMA 4X	
Housing		UL Enclosure Type 4X	
EMC		CE according to 2014/30/EU	
Certification IEC/EN		IEC/EN 60730-1 and IEC/EN 60730-2-14	
UL Approval		cULus according to UL60730-1A, UL60730-2-14 and CAN/CSA E60730-1 The UL marking on the actuator depends on the production site, the device is UL-compliant in any case	
Type of action		Type 1.AA	
Rated impulse voltage supply / control		0.8 kV	
Pollution degree		4	
Ambient humidity		Max. 100% RH	
Ambient temperature		-30...50°C [-22...122°F]	
Ambient temperature note		-40...50°C [104...122°F] for actuator with integrated heating	
Storage temperature		-40...80°C [-40...176°F]	
Servicing		maintenance-free	
Weight		Weight	4.3 kg

Safety notes



- This device has been designed for use in stationary heating, ventilation and air-conditioning systems and must not be used outside the specified field of application, especially in aircraft or in any other airborne means of transport.
- Only authorised specialists may carry out installation. All applicable legal or institutional installation regulations must be complied with during installation.
- Junction boxes must at least correspond with housing IP degree of protection!
- The cover of the protective housing may be opened for adjustment and servicing. When it is closed afterwards, the housing must seal tight (see installation instructions).
- The device may only be opened at the manufacturer's site. It does not contain any parts that can be replaced or repaired by the user.
- The cables must not be removed from the device installed in the interior.
- To calculate the torque required, the specifications supplied by the damper manufacturers concerning the cross-section and the design, as well as the installation situation and the ventilation conditions must be observed.
- The device contains electrical and electronic components and must not be disposed of as household refuse. All locally valid regulations and requirements must be observed.
- The device is not designed for applications where chemical influences (gases, fluids) are present or for utilisation in corrosive environments in general.
- The actuator may not be used in plenary applications (e.g. suspended ceilings or raised floors).
- The materials used may be subject to external influences (temperature, pressure, construction fastening, effect of chemical substances, etc.), which cannot be simulated in laboratory tests or field trials. In case of doubt, we definitely recommend that you carry out a test. This information does not imply any legal entitlement. Belimo will not be held liable and will provide no warranty.
- Flexible metallic cable conduits or threaded cable conduits of equal value are to be used for UL (NEMA) Type 4X applications.
- When used under high UV loads, e.g. extreme sunlight, the use of flexible metallic or equivalent cable conduits is recommended.

Product features

Fields of application	The actuator is particularly suitable for utilisation in outdoor applications and is protected against the following weather conditions: <ul style="list-style-type: none"> - UV radiation - Rain / Snow - Dirt / Dust - Air humidity - Alternating climate / frequent and severe temperature fluctuations (Recommendation: use the actuator with integrated factory-installed heating which can be ordered separately to prevent internal condensation)
Operating mode	Conventional operation: The actuator is connected with a standard control signal of 0...10 V and moves the damper to the operating position at the same time as tensioning the return spring. The damper is turned back to the fail-safe position by spring force when the supply voltage is interrupted. Operation on Bus: The actuator receives its digital control signal from the higher level controller via the MP-Bus and drives to the position defined. Connection U serves as communication interface and does not supply an analogue measuring voltage.
Converter for sensors	Connection option for a sensor (passive or active sensor or switching contact). The MP actuator serves as an analogue/digital converter for the transmission of the sensor signal via MP-Bus to the higher level system.
Parametrisable actuators	The factory settings cover the most common applications. Single parameters can be modified with Belimo Assistant 2 or ZTH EU.

Product features

Simple direct mounting	Simple direct mounting on the damper shaft with a universal shaft clamp, supplied with an anti-rotation device to prevent the actuator from rotating.
Manual override	By using the hand crank the damper can be actuated manually and engaged with the locking switch at any position. Unlocking is carried out manually or automatically by applying the operating voltage. The housing cover must be removed for manual override.
Adjustable angle of rotation	Adjustable angle of rotation with mechanical end stops.
High functional reliability	The actuator is overload protected, requires no limit switches and automatically stops when the end stop is reached.
Home position	The first time the supply voltage is switched on, i.e. at the time of commissioning, the actuator carries out a synchronisation. The synchronisation is in the home position (0%). The actuator then moves into the position defined by the control signal.
Adaptation and synchronisation	An adaptation can be triggered manually by pressing the "Adaptation" button or with the PC-Tool. Both mechanical end stops are detected during the adaptation (entire setting range). Automatic synchronisation after actuating the hand crank is programmed. The synchronisation is in the home position (0%). The actuator then moves into the position defined by the control signal. A range of settings can be made using Belimo Assistant 2.
Flexible signalling	If a combination with the following electrical accessories is required, please contact your Belimo representative! S2A-F Auxiliary switch 2 x SPDT P200A-F Feedback potentiometer 200 Ω P1000A-F Feedback potentiometer 1 kΩ

Accessories

Tools	Description	Type
	Service tool, with ZIP-USB function, for parametrisable and communicative Belimo actuators, VAV controller and HVAC performance devices	ZTH EU
	Service tool for wired and wireless setup, on-site operation, and troubleshooting.	Belimo Assistant 2
	Adapter for Service-Tool ZTH	MFT-C
	Connecting cable 5 m, A: RJ11 6/4 ZTH EU, B: 6-pin for connection to service socket	ZK1-GEN
	Connecting cable 5 m, A: RJ11 6/4 ZTH EU, B: free wire end for connection to MP/PP terminal	ZK2-GEN
Electrical accessories	Description	Type
	Signal converter voltage/current 100 kΩ 4...20 mA, Supply AC/DC 24 V	Z-UIC
	Positioner for wall mounting	SGA24
	Positioner for built-in mounting	SGE24
	Positioner for front-panel mounting	SGF24
	Positioner for wall mounting	CRP24-B1
	MP-Bus power supply for MP actuators	ZN230-24MP
Gateways	Description	Type
	Gateway MP to BACnet MS/TP	UK24BAC
	Gateway MP to Modbus RTU	UK24MOD
Mechanical accessories	Description	Type
	Cable gland for cable diameter ø4...10 mm	Z-KB-PG11
Options ex works only	Description	Type
	Heater, with adjustable thermostat	HT24-FG

Accessories

Description

Heater, with mechanical humidistat

Type

HH24-FG

Electrical installation



Supply from isolating transformer.

Parallel connection of other actuators possible. Observe the performance data.

Wire colours:

- 1 = black
- 2 = red
- 3 = white
- 5 = orange

MP-Bus

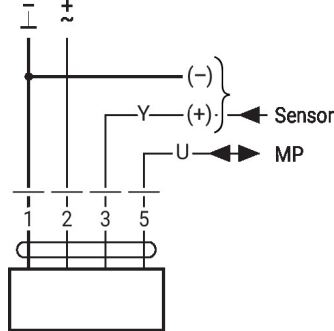

AC/DC 24 V, modulating

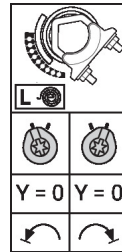
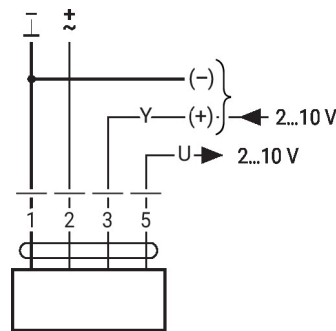

Further electrical installations

Functions with basic values (conventional mode)

Override control with AC 24 V with relay contacts

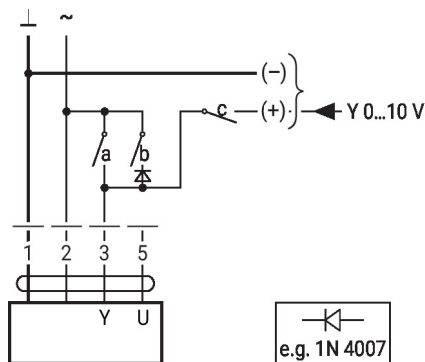

1	2	a	b	c	
					0 %
					ZS 50%
					100%
					Y

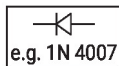

Override control with AC 24 V with rotary switch

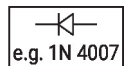
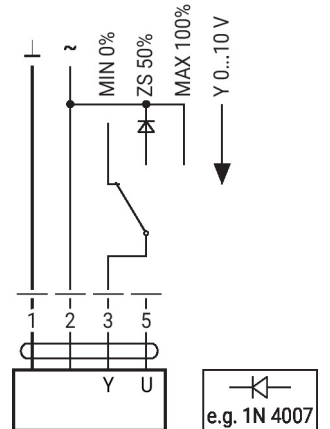

Functions with basic values (conventional mode)

Control remotely 0...100% with positioner SG..

Minimum limit with positioner SG..

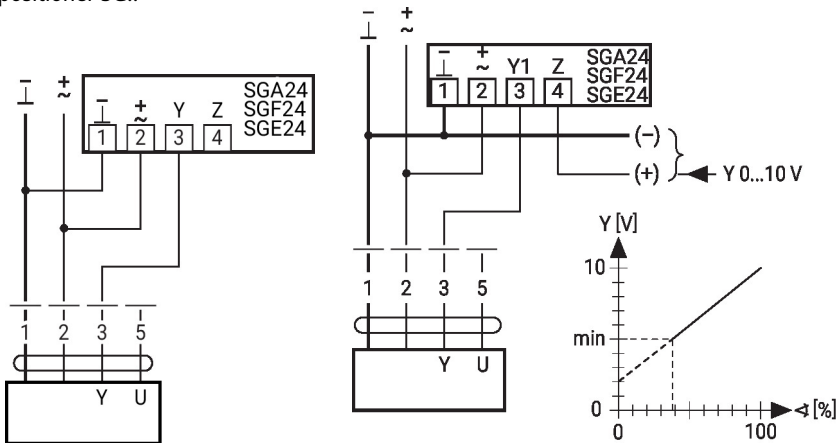

Primary/secondary operation (position-dependent)

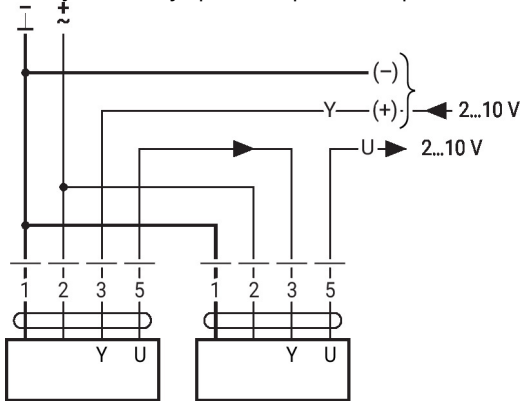

Control with 4...20 mA via external resistor

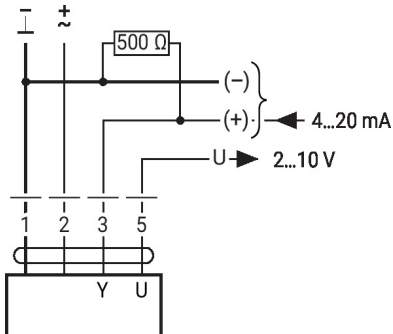

Caution:

The operating range must be set to DC 2...10 V.

The 500 Ohm resistor converts the 4...20 mA current signal to a voltage signal DC 2...10 V.

Functions with basic values (conventional mode)

Functional check

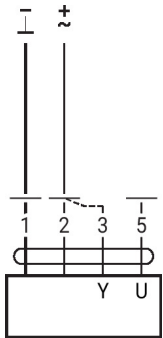
Procedure

1. Connect 24 V to connections 1 and 2
2. Disconnect connection 3:
 - With direction of rotation 0: Actuator rotates to the left
 - With direction of rotation 1: Actuator rotates to the right
3. Short-circuit connections 2 and 3:
 - Actuator runs in opposite direction

MP-Bus

Connection on the MP-Bus

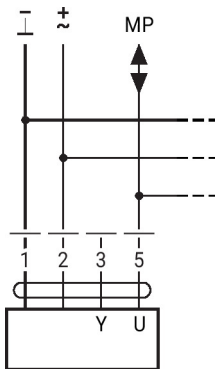

Max. 8 MP-Bus nodes

Connection of active sensors

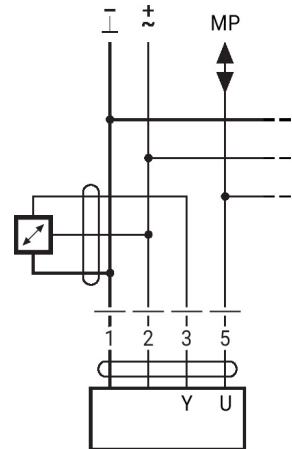

- Supply AC/DC 24 V
- Output signal 0...10 V (max. 0...32 V)
- Resolution 30 mV

Connection of external switching contact

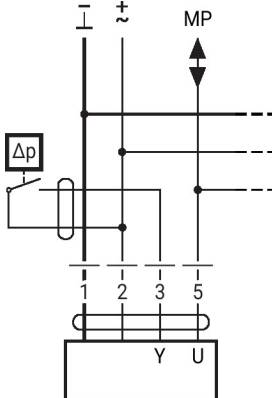

- Switching current 16 mA @ 24 V
- Start point of the operating range must be parametrised on the MP actuator as ≥ 0.5 V

MP-Bus

Connection of passive sensors

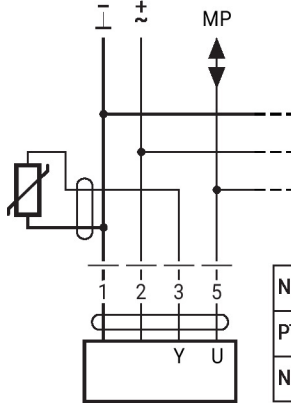

Ni1000	-28...+98°C	850...1600 Ω ²⁾
PT1000	-35...+155°C	850...1600 Ω ²⁾
NTC	-10...+160°C ¹⁾	200 Ω...60 kΩ ²⁾

1) Depending on the type
 2) Resolution 1 Ohm
 Compensation of the measured value is recommended

Functions with specific parameters (Parametrisation necessary)

Override control and limiting with AC 24 V with relay contacts

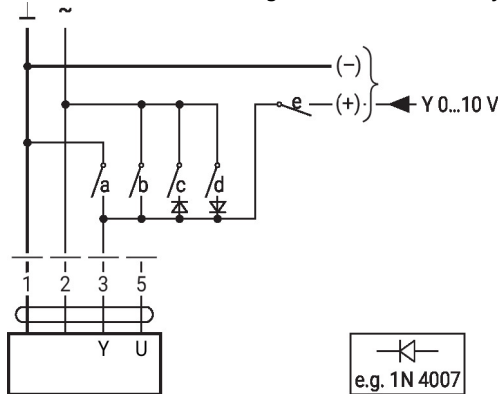

1	2	a	b	c	d	e	
⎓	⎓	⎓	⎓	⎓	⎓	⎓	Close
⎓	⎓	⎓	⎓	⎓	⎓	⎓	MIN
⎓	⎓	⎓	⎓	⎓	⎓	⎓	ZS
⎓	⎓	⎓	⎓	⎓	⎓	⎓	MAX
⎓	⎓	⎓	⎓	⎓	⎓	⎓	Open
⎓	⎓	⎓	⎓	⎓	⎓	⎓	Y

Control open/close

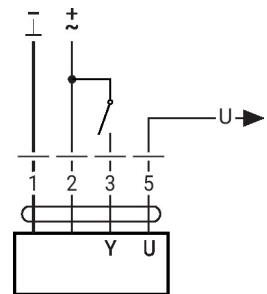

Override control and limiting with AC 24 V with rotary switch

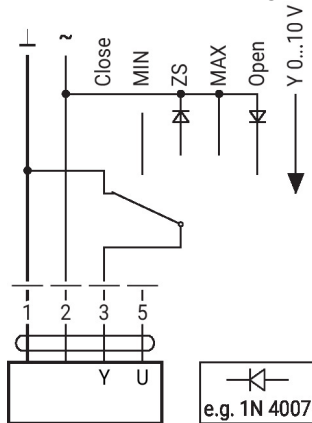

e.g. 1N 4007

Caution:
 The "Close" function is only guaranteed if the start point of the operating range is defined as min. 0.5 V.

Further electrical installations

Functions with specific parameters (Parametrisation necessary)

Control 3-point with AC 24 V

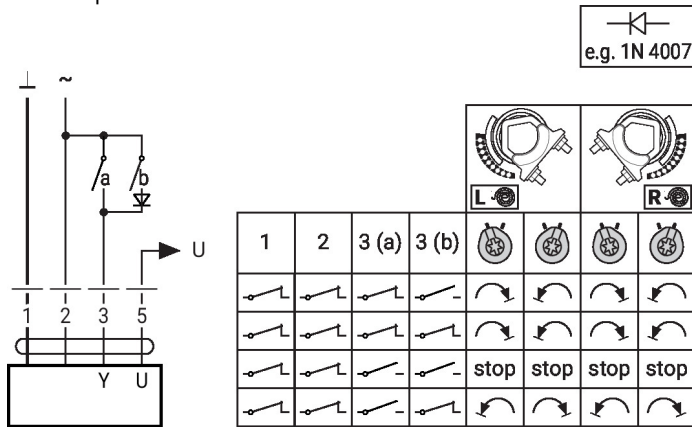

Operating controls and indicators

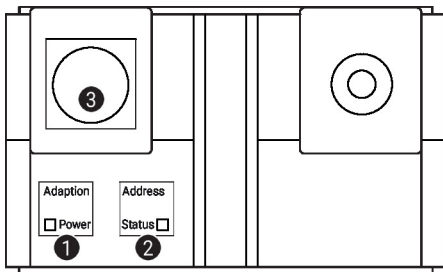

1 Membrane key and LED display green

Off: No power supply or malfunction

On: In operation

Press button: Triggers angle of rotation adaptation, followed by standard mode

2 Membrane key and LED display yellow

Off: Standard mode

On: Adaptation or synchronisation process active

Flickering: MP-Bus communication active

Flashing: Request for addressing from MP client

Press button: Confirmation of the addressing

3 Service plug

For connecting parametrisation and service tools

Operating elements

The manual override, locking switch and direction of rotation switch elements are available on both sides

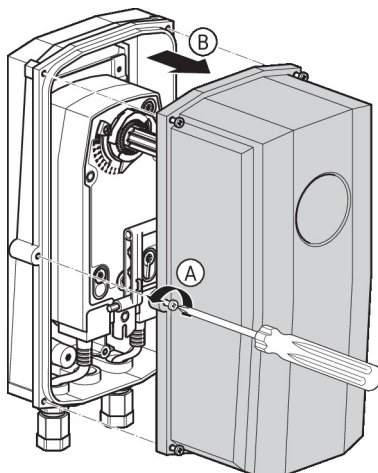

Service

Wired connection The device can be parametrised by ZTH EU via the service socket.
For an extended parametrisation, Belimo Assistant 2 can be connected.

Connection ZTH EU / Belimo Assistant 2

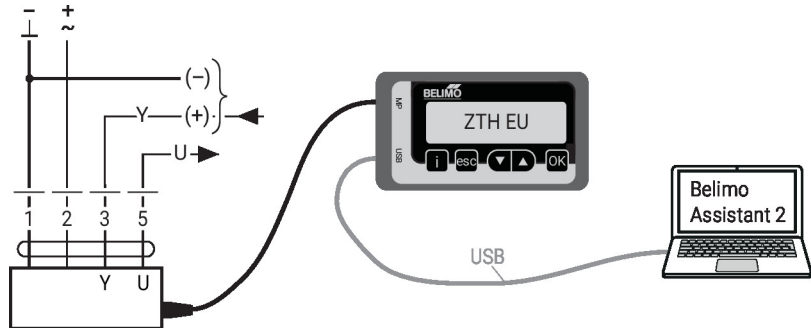

Dimensions

Spindle length

	-
	16...105 (ø12...19)
	16...45 (ø19...26.7)

Clamping range

	12...22	12...18
	22...26.7	12...18

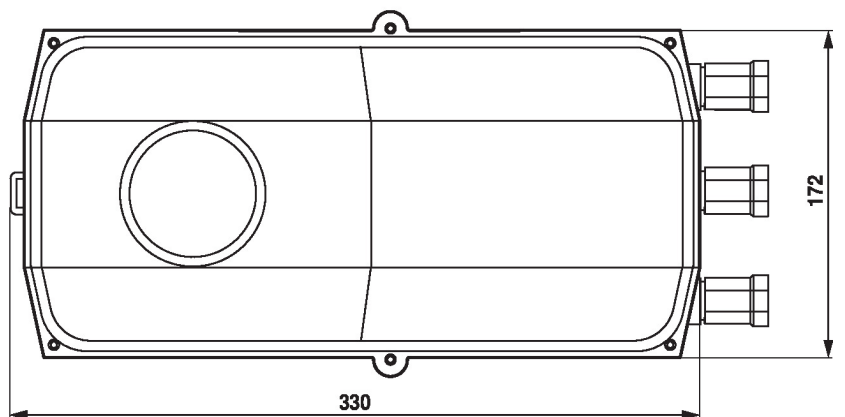
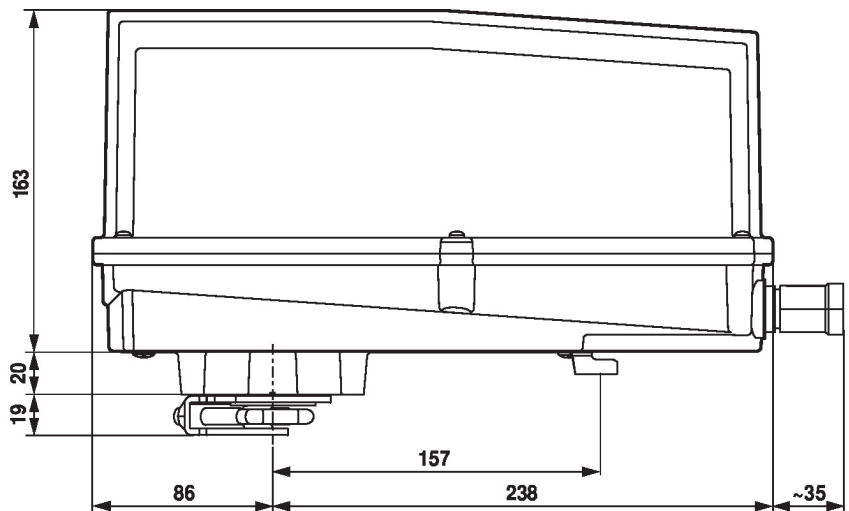

Further documentation

- Overview MP Cooperation Partners
- Tool connections
- Introduction to MP-Bus Technology
- Quick Guide – Belimo Assistant 2

Application notes

- For digital control of actuators in VAV applications patent EP 3163399 must be considered.