

Communicative rotary actuator with fail-safe for ball valves

- Torque motor 4 Nm
- Nominal voltage AC/DC 24 V
- Control modulating, communicative 2...10 V variable
- Position feedback 2...10 V variable
- Communication via Belimo MP-Bus
- Conversion of sensor signals
- Deenergised open (NO)
- PWIS/LABS-compliant according to VDMA 24364



Technical data

Electrical data	Nominal voltage	AC/DC 24 V
	Nominal voltage frequency	50/60 Hz
	Nominal voltage range	AC 19.2...28.8 V / DC 21.6...28.8 V
	Power consumption in operation	6 W
	Power consumption in rest position	2.5 W
	Power consumption for wire sizing	10 VA
	Connection supply / control	Cable 1 m, 4x 0.75 mm ²
	Parallel operation	Yes (note the performance data)
Data bus communication	Communicative control	MP-Bus
	Number of nodes	MP-Bus max. 8
Functional data	Torque motor	4 Nm
	Torque fail-safe	4 Nm
	Operating range Y	2...10 V
	Input impedance	100 kΩ
	Operating range Y variable	Start point 0.5...30 V End point 2.5...32 V
	Operating modes optional	Open/close 3-point (AC only) Modulating (DC 0...32 V)
	Position feedback U	2...10 V
	Position feedback U note	Max. 0.5 mA
	Position feedback U variable	Start point 0.5...8 V End point 2.5...10 V
	Position accuracy	±5%
	Direction of motion motor	Y = 0 (0 V = A – AB = 0%)
	Direction of motion fail-safe	Deenergised NO, valve open (A – AB = 100%)
	Direction of motion note	for valves with L-bore (A – AB = 0%)
	Manual override	No
	Running time motor	75 s / 90°
	Running time motor variable	75...300 s
	Running time fail-safe	<20 s @ -20...50°C / <60 s @ -30°C
	Sound power level, motor	45 dB(A)
Adaptation setting range	manual (automatic on first power-up)	
Adaptation setting range variable	No action Adaptation when switched on Adaptation after using the rotation switch	

Technical data

Functional data	Override control	MAX (maximum position) = 100% MIN (minimum position) = 0% ZS (intermediate position, AC only) = 50%
	Override control variable	MAX = (MIN + 33%)...100% MIN = 0%...(MAX - 33%) ZS = MIN...MAX
	Position indication	Mechanical
	Service life	Min. 60'000 fail-safe positions
	Safety data	Protection class IEC/EN
Degree of protection IEC/EN		IP54
EMC		CE according to 2014/30/EU
Certification IEC/EN		IEC/EN 60730-1 and IEC/EN 60730-2-14
PWIS/LABS-conformity		According to VDMA 24364 (test class C1) Approved for use in zone II Cleaning with low-pressure plasma treatment
Type of action		Type 1
Rated impulse voltage supply / control		0.8 kV
Pollution degree		3
Ambient humidity		Max. 95% RH, non-condensing
Ambient temperature		-30...50°C [-22...122°F]
Storage temperature		-10...40°C [14...104°F]
Servicing		maintenance-free
Weight		Weight

Safety notes

- This device has been designed for use in stationary heating, ventilation and air-conditioning systems and must not be used outside the specified field of application, especially in aircraft or in any other airborne means of transport.
- Outdoor application: only possible in case that no (sea) water, snow, ice, insolation or aggressive gases interfere directly with the device and that it is ensured that the ambient conditions remain within the thresholds according to the data sheet at any time.
- Only authorised specialists may carry out installation. All applicable legal or institutional installation regulations must be complied with during installation.
- The device may only be opened at the manufacturer's site. It does not contain any parts that can be replaced or repaired by the user.
- Cables must not be removed from the device.
- The device contains electrical and electronic components and must not be disposed of as household refuse. All locally valid regulations and requirements must be observed.
- PWIS/LABS-conformity is guaranteed as long as the packaging is unopened. Once the PWIS/LABS-compliant packaging has been opened, the proper handling of the products is the responsibility of the customer. PWIS/LABS-conformity of unopened products is guaranteed for a period of one year after cleaning, provided they are handled properly, professionally and cleanly. Proof of proper, professional and clean handling is the responsibility of the purchaser. Ensure that the required cleanliness of the products is maintained. Do not touch the products with bare hands. Belimo accepts no liability for the consequences resulting from the contamination of a product caused by the customer.

Product features

Operating mode	<p>Conventional operation:</p> <p>The actuator is connected with a standard control signal 0...10 V. The actuator moves the valve to the operating position at the same time as tensioning the return spring. The valve is turned back to the fail-safe position by spring force when the supply voltage is interrupted.</p> <p>Operation on Bus:</p> <p>The actuator receives its digital control signal from the higher level controller via the MP-Bus and drives to the position defined. Connection U serves as communication interface and does not supply an analogue measuring voltage.</p>
Converter for sensors	<p>Connection option for a sensor (passive or active sensor or switching contact). The MP actuator serves as an analogue/digital converter for the transmission of the sensor signal via MP-Bus to the higher level system.</p>
Parametrisable actuators	<p>The factory settings cover the most common applications. Single parameters can be modified with the Belimo service tools MFT-P or ZTH EU.</p>
Simple direct mounting	<p>Simple direct mounting on the ball valve with only one screw. The mounting orientation in relation to the ball valve can be selected in 90° steps.</p>
Home position	<p>The first time the supply voltage is switched on, i.e. at the time of commissioning, the actuator carries out an adaptation, which is when the operating range and position feedback adjust themselves to the mechanical setting range.</p> <p>The actuator then moves into the position defined by the control signal.</p> <p>Factory setting: R (counter-clockwise rotation).</p>
Adaptation and synchronisation	<p>An adaptation can be triggered manually by switching the direction of rotation switch from the left to the right twice within 5s or with the PC-Tool. Both mechanical end stops are detected during the adaptation (entire setting range). Automatic synchronisation after actuating the direction of rotation switch once is programmed. The synchronisation is in the home position (0%).</p> <p>A range of settings can be adapted using the PC-Tool (see MFT-P documentation)</p>

Accessories

Tools	Description	Type
	Service tool, with ZIP-USB function, for parametrisable and communicative Belimo actuators, VAV controller and HVAC performance devices	ZTH EU
	Belimo PC-Tool, Software for adjustments and diagnostics	MFT-P
	Adapter for Service-Tool ZTH	MFT-C
	Connecting cable 5 m, A: RJ11 6/4 ZTH EU, B: 6-pin for connection to service socket	ZK1-GEN
	Connecting cable 5 m, A: RJ11 6/4 ZTH EU, B: free wire end for connection to MP/PP terminal	ZK2-GEN
Electrical accessories	Description	Type
	MP-Bus power supply for MP actuators	ZN230-24MP
Gateways	Description	Type
	Gateway MP to BACnet MS/TP	UK24BAC
	Gateway MP to Modbus RTU	UK24MOD

Electrical installation

Supply from isolating transformer.
Parallel connection of other actuators possible. Observe the performance data.

Electrical installation

Wire colours:

- 1 = black
- 2 = red
- 3 = white
- 5 = white

Wiring diagrams

MP-Bus

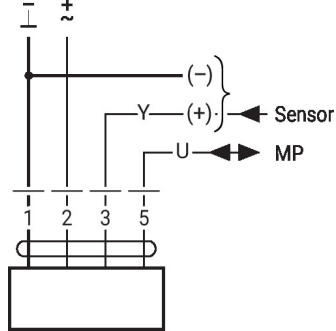

AC/DC 24 V, modulating

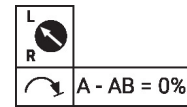
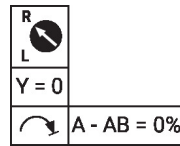
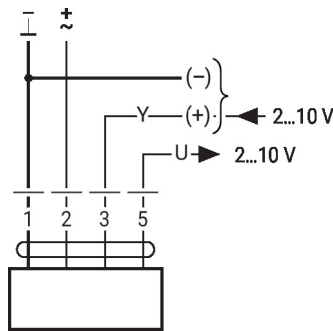

Further electrical installations

Functions with basic values (conventional mode)

Override control with AC 24 V with relay contacts

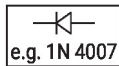
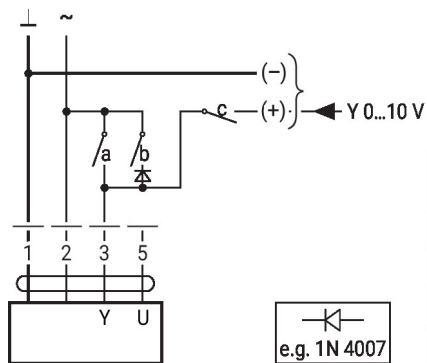

Override control with AC 24 V with rotary switch

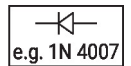
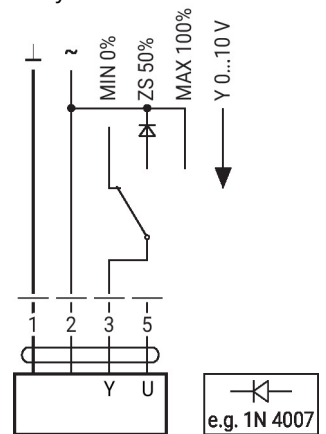

Control remotely 0...100% with positioner SG..

Minimum limit with positioner SG..

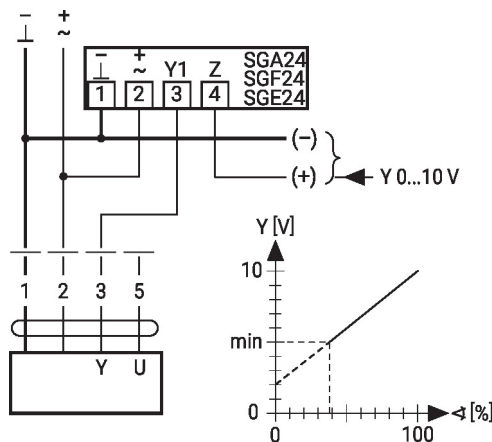
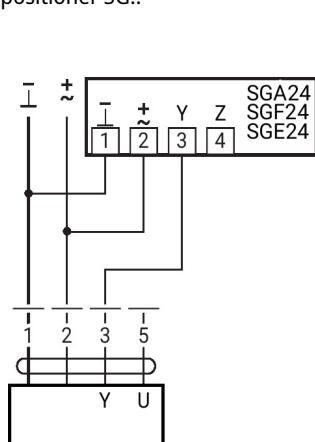

Functions with basic values (conventional mode)

Primary/secondary operation (position-dependent)

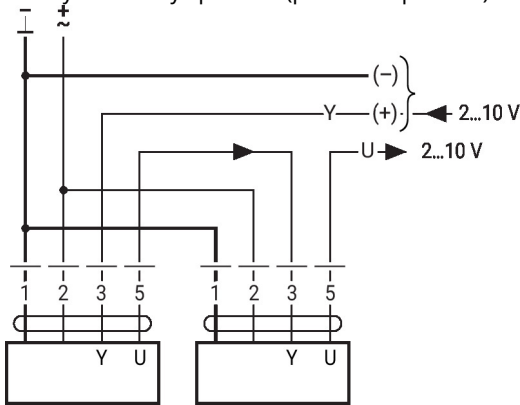

Control with 4...20 mA via external resistor

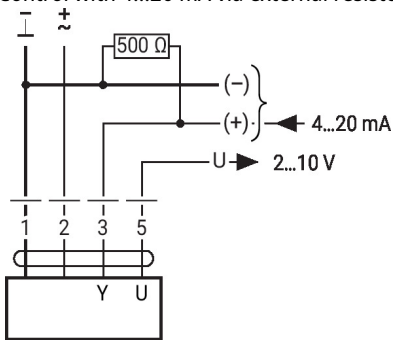

Caution:

The operating range must be set to DC 2...10 V.

The 500 Ohm resistor converts the 4...20 mA current signal to a voltage signal DC 2...10 V.

Functional check

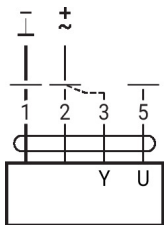

Procedure

1. Connect 24 V to connections 1 and 2
2. Disconnect connection 3:
 - with direction of rotation L: Actuator rotates to the left
 - with direction of rotation R: Actuator rotates to the right
3. Short-circuit connections 2 and 3:
 - Actuator runs in opposite direction

Functions with specific parameters (Parametrisation necessary)

Connection on the MP-Bus

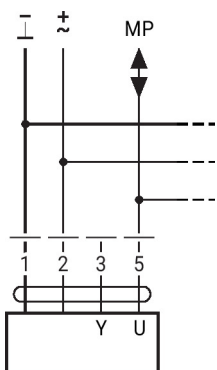

Max. 8 MP-Bus nodes

Connection of active sensors

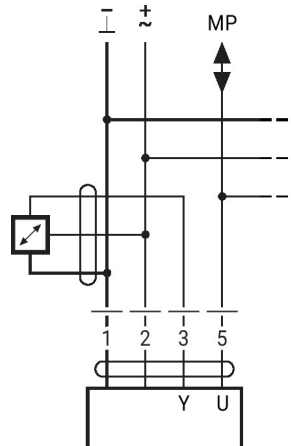

- Supply AC/DC 24 V
- Output signal 0...10 V (max. 0...32 V)
- Resolution 30 mV

Functions with specific parameters (Parametrisation necessary)

Connection of external switching contact

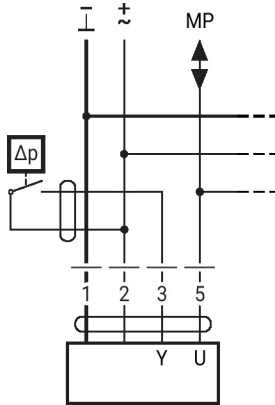

- Switching current 16 mA @ 24 V
- Start point of the operating range must be parametrised on the MP actuator as ≥ 0.5 V

Connection of passive sensors

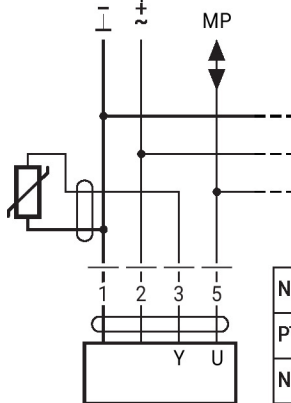

Ni1000	-28...+98°C	850...1600 Ω ²⁾
PT1000	-35...+155°C	850...1600 Ω ²⁾
NTC	-10...+160°C ¹⁾	200 Ω...60 kΩ ²⁾

- 1) Depending on the type
 - 2) Resolution 1 Ohm
- Compensation of the measured value is recommended

Override control and limiting with AC 24 V with relay contacts

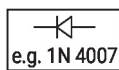
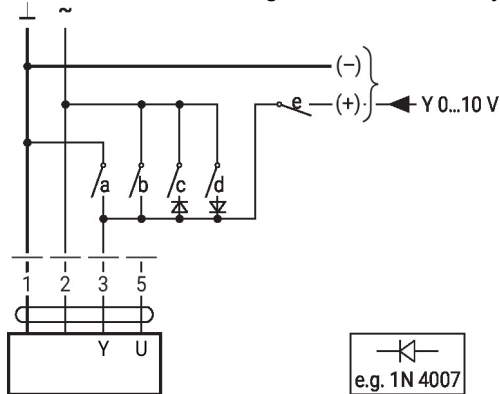

1	2	a	b	c	d	e	
⎓	⎓	⎓	⎓	⎓	⎓	⎓	Close
⎓	⎓	⎓	⎓	⎓	⎓	⎓	MIN
⎓	⎓	⎓	⎓	⎓	⎓	⎓	ZS
⎓	⎓	⎓	⎓	⎓	⎓	⎓	MAX
⎓	⎓	⎓	⎓	⎓	⎓	⎓	Open
⎓	⎓	⎓	⎓	⎓	⎓	⎓	Y

Control open/close

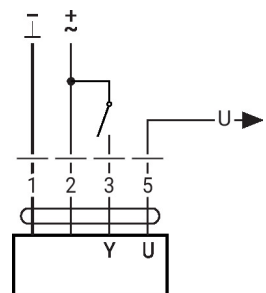

Further electrical installations

Functions with specific parameters (Parametrisation necessary)

Override control and limiting with AC 24 V with rotary switch

Control 3-point with AC 24 V

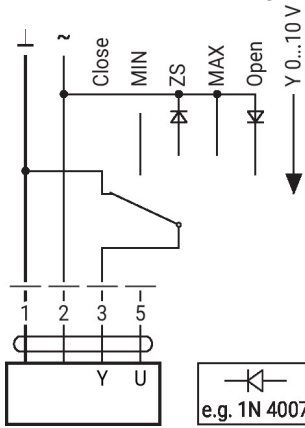

Caution:
The "Close" function is only guaranteed if the start point of the operating range is defined as min. 0.5 V.

1	2	3		

Operating controls and indicators

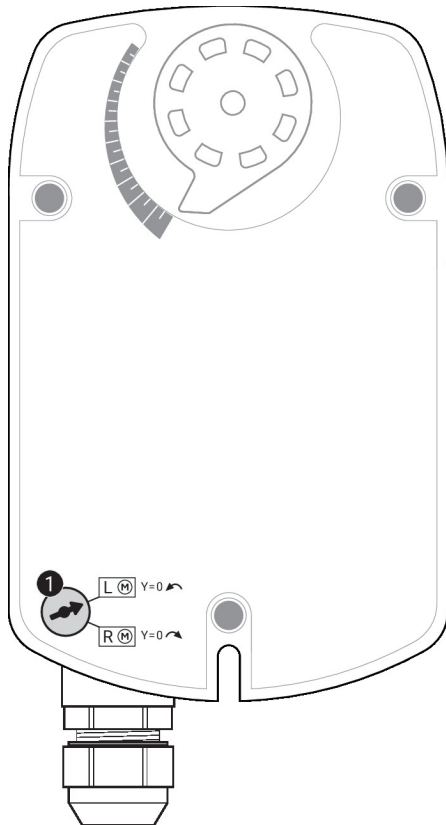

- 1 **MP addressing**
Move direction of rotation switch in opposite position and backwards (within 4 seconds)

Service

Tool connection The actuator can be parametrised by ZTH EU via terminal connection.
For extended parametrisation the PC tool can be connected.

Connection ZTH EU / PC-Tool

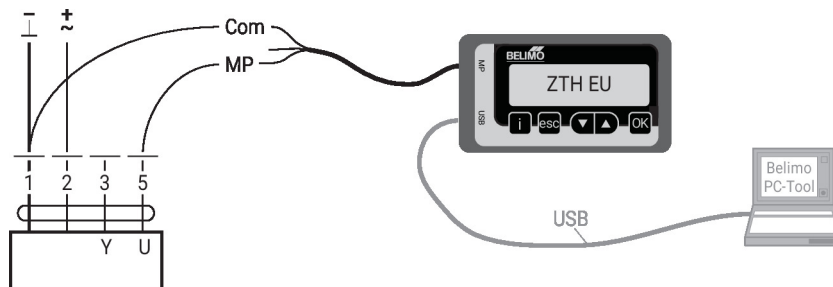

Dimensions

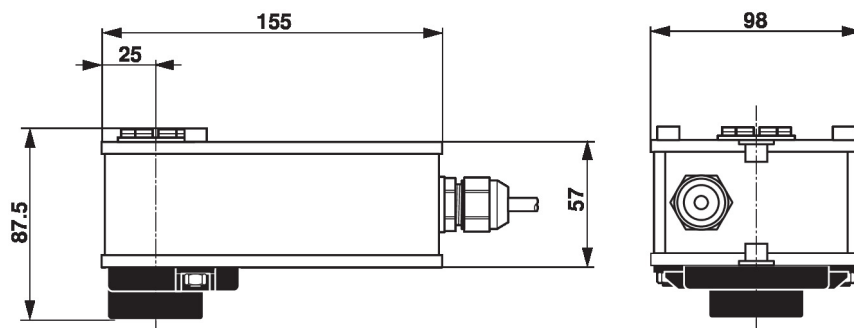

Further documentation

- Overview MP Cooperation Partners
- Tool connections
- Introduction to MP-Bus Technology
- The complete product range for water applications
- Data sheets for ball valves
- Installation instructions for actuators and/or ball valves
- General notes for project planning