

**Ball joint**

- suitable for damper crank arm KH8 / KH10

**Technical data**

<b>Weight</b>	Weight	0.058 kg
---------------	--------	----------

**Safety notes**

- This accessory has been designed for use in stationary heating, ventilation and air-conditioning systems and must not be used outside the specified field of application, especially in aircraft or in any other airborne means of transport.
- Only authorised specialists may carry out installation. All applicable legal or institutional installation regulations must be complied with during installation.
- The accessory may not be disposed of as household refuse. All locally valid regulations and requirements must be observed.

**Product features**

<b>Used materials</b>	Galvanised steel
-----------------------	------------------

Product features

**Application** Suitable for LF.., GK..A, GM..A, LMQ..A, NF..A, NKQ..A, NM..A, NMC..A, NMQ..A, SF..A, SM..A, SMC..A, SMD..A, SMQ..A, TF..

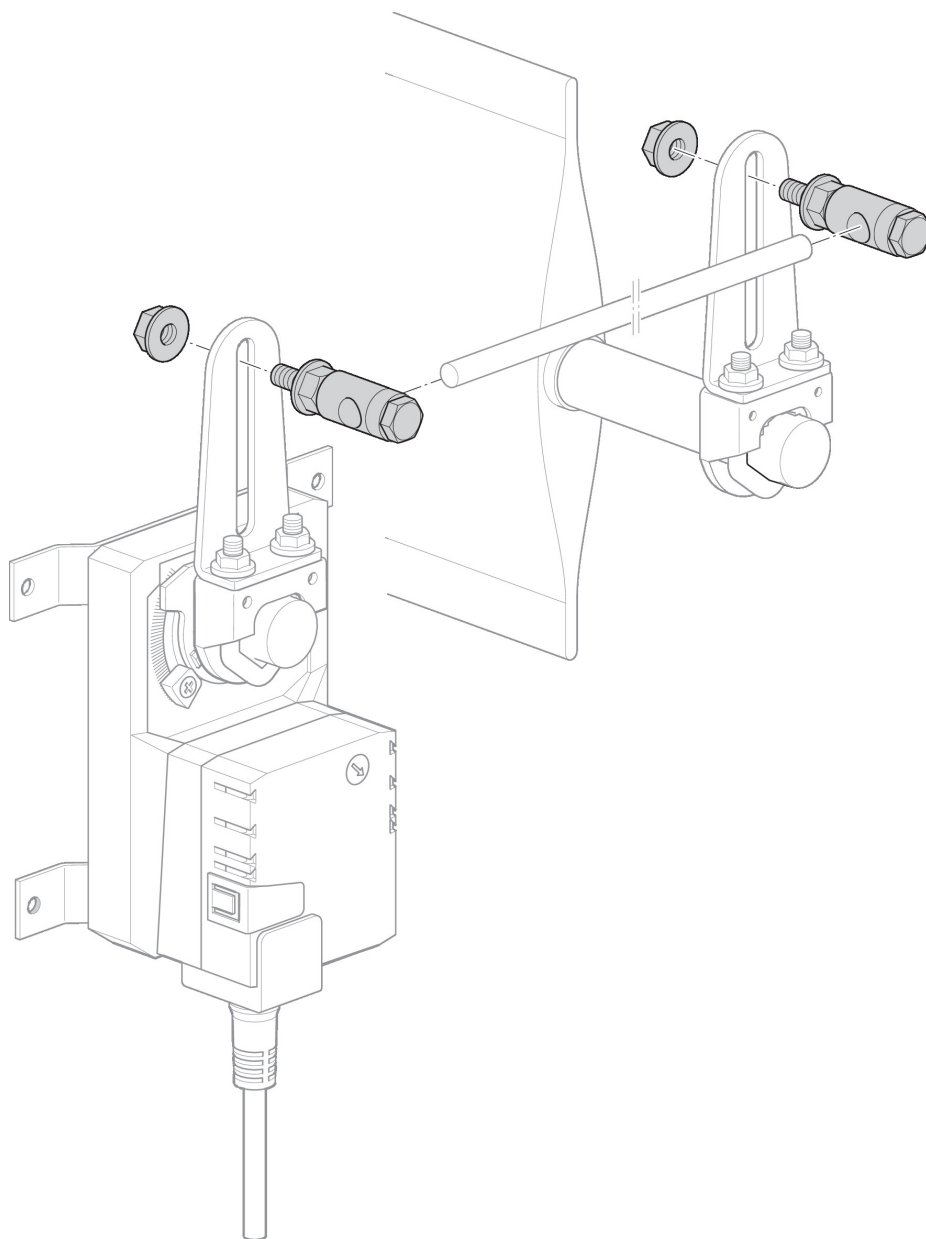

Dimensions

