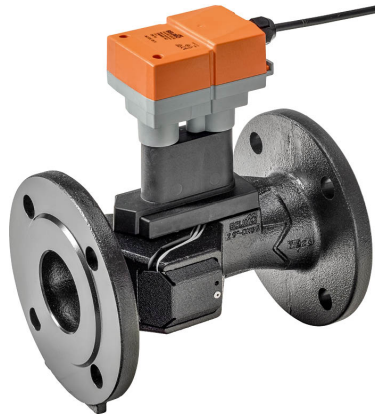

**Flow sensor**

Calibrated ultrasonic flow sensor, temperature and glycol compensated. With DC 0.5...10 V output signal. This sensor can be used in closed cold and warm water systems and is robust against dirt and magnetite. There is also a low pressure drop across the sensor.

**Type Overview**

Type	DN	FS [l/s]	$\Delta p$ [kPa]	PN	Output signal active volumetric flow
FM065F-SZ	65	9.6	12	16	0.5...10 V
FM080F-SZ	80	13.6	13	16	0.5...10 V
FM100F-SZ	100	24.0	12	16	0.5...10 V
FM125F-SZ	125	37.5	13	16	0.5...10 V
FM150F-SZ	150	54.0	15	16	0.5...10 V

FS: Full scale, maximum flow

$\Delta p$ : Pressure drop at FS

**Technical data**

<b>Electrical data</b>	Nominal voltage	AC/DC 24 V
	Nominal voltage frequency	50/60 Hz
	Nominal voltage range	AC 19.2...28.8 V / DC 21.6...28.8 V
	Power consumption AC	1 VA
	Power consumption DC	0.5 W
	Connection supply	Cable , 3 x 0.75 mm <sup>2</sup>
<b>Functional data</b>	Sensor technology	Ultrasonic time-of-flight (with glycol and temperature compensation)
	Application	Water
	Voltage output	1 x 0...10 V, max. load 1 mA
	PN	16
	Pipe connection	Flange according to EN 1092-2
	Installation orientation	upright to horizontal
	Servicing	maintenance-free
<b>Measuring data</b>	Measured values	Flow
	Measuring fluid	Water and water-glycol mixtures
	Measuring principle	Ultrasonic volumetric flow measurement
<b>Specification Flow</b>	Min. flow measurement	1% of FS
	Measuring accuracy flow	±2% of the measured value (20...100% FS) @ 20°C / glycol 0% vol. ±0.4% of FS (0...20% FS) @ 20°C / glycol 0% vol.

**Technical data**

<b>Specification Flow</b>	Measuring accuracy flow note	±6% of the measured value (20...100% FS) @ -20...120°C / glycol 0...50% vol. ±1.2% of FS (0...20% FS) @ -20...120°C / glycol 0...50% vol.
	Measurement repeatability	±0.5% (Flow)
<b>Safety data</b>	Protection class IEC/EN	III, Safety Extra-Low Voltage (SELV)
	Power source UL	Class 2 Supply
	Degree of protection IEC/EN	IP54
	Degree of protection NEMA/UL	NEMA 2
	Enclosure	UL Enclosure Type 2
	EMC	CE according to 2014/30/EU
	Certification IEC/EN	IEC/EN 60730-1:11 and IEC/EN 60730-2-15:10
	Quality Standard	ISO 9001
	Type of action	Type 1
	Rated impulse voltage supply	0.8 kV
	Pollution degree	3
	Ambient humidity	Max. 95% RH, non-condensing
	Ambient temperature	-30...50°C [-22...122°F]
	Fluid temperature	-20...120°C [-4...250°F] At a fluid temperature of <2°C [<36°F], frost protection must be guaranteed
Storage temperature	-40...80°C [-40...176°F]	
<b>Materials</b>	Flow measuring pipe	EN-GJL-250 (GG 25), with protective paint

**Safety notes**

This device has been designed for use in stationary heating, ventilation and air-conditioning systems and must not be used outside the specified field of application, especially in aircraft or in any other airborne means of transport.

Outdoor applications: Only possible where (sea) water, snow, ice, sunlight or aggressive gases cannot interfere directly with the device and it can be guaranteed that the ambient conditions remain at all times within the thresholds according to the data sheet.

Only authorised specialists may carry out installation. All applicable legal or institutional installation regulations must be complied with during installation.

The device contains electrical and electronic components and must not be disposed of as household refuse. All locally valid regulations and requirements must be observed.

**Product Features**

**Operating mode** The ultrasonic flow sensor is equipped with a flow pipe, four flow transmitters and an electronic circuit. A temperature sensor is mounted in the flow pipe to compensate the temperature effects.

A sensor error occurs when the ultrasonic path is interrupted (air bubbles in the system, connection to ultrasonic transducers interrupted).

**Patented glycol compensation** Glycol changes the viscosity of the heat transfer fluid and as a result affects the measured volumetric flow. Without glycol compensation, volumetric flow measurements can show errors of as much as 30 percent. The patented automatic glycol compensation significantly reduces the degree of measurement error.

Installation notes

**Permissible installation orientation** The sensor can be installed upright to horizontal. The sensor may not be installed in a hanging position.

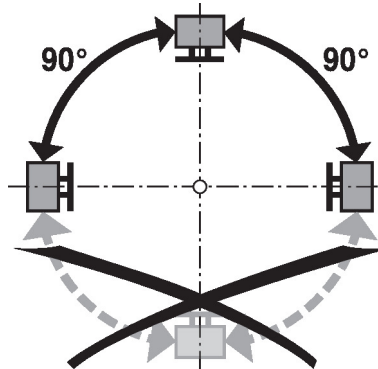

**Installation in return** Installation in the return is recommended.

**Inlet section** In order to achieve the specified measuring accuracy, a flow-calming section or inflow section in the direction of the flow is to be provided upstream from the flow sensor. Its dimensions should be at least 5x DN.

DN	L min.
65	5 x 65 mm = 325 mm
80	5 x 80 mm = 400 mm
100	5 x 100 mm = 500 mm
125	5 x 125 mm = 625 mm
150	5 x 150 mm = 750 mm

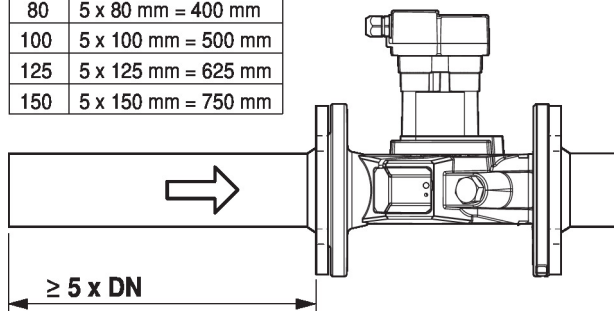

**Water quality requirements** The water quality requirements specified in VDI 2035 must be adhered to.

**Servicing** Sensors are maintenance-free.  
 Before any service work on the sensor is carried out, it is essential to isolate the sensor from the power supply (by unplugging the electrical cables if necessary). Any pumps in the part of the piping system concerned must also be switched off and the appropriate slide valves closed (allow all components to cool down first if necessary and always reduce the system pressure to ambient pressure level).  
 The system must not be returned to service until the sensor has been correctly reassembled in accordance with the instructions and the pipeline has been refilled by professionally trained personnel.

**Flow direction** The direction of flow, specified by an arrow on the housing, is to be complied with, since otherwise the flow rate will be measured incorrectly.

Wiring diagram



Notes

Supply from isolating transformer.

## Wiring diagram

AC/DC 24 V, Output signal

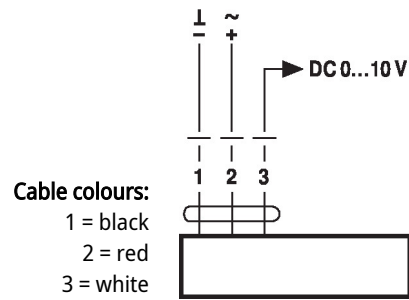

**Detailed documentation** Voltage output note:  
0 V = Missing power supply  
0.3 V = Sensor error  
0.5 V = 0% of FS or negative flow  
10 V = 100% of FS

## Dimensions

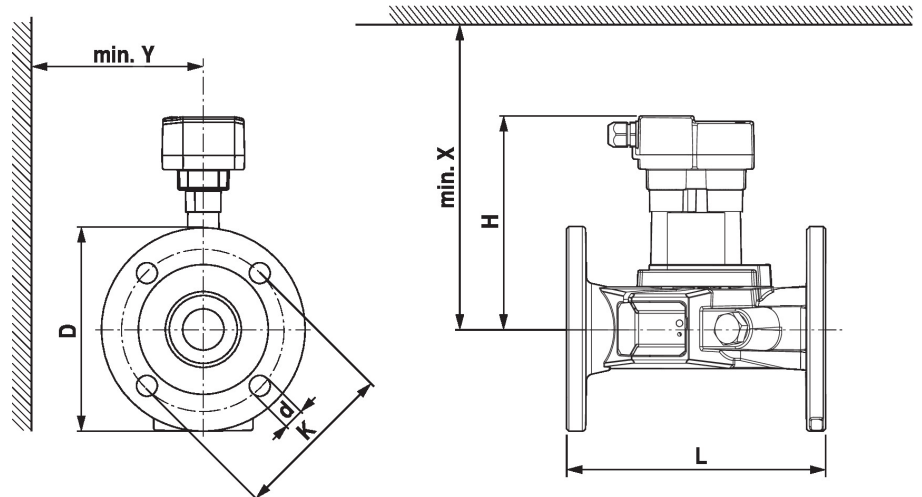

Type	DN	DN ["]	L [mm]	H [mm]	D [mm]	d [mm]	K [mm]	X [mm]	Y [mm]	Weight
FM065F-SZ	65	2 1/2	240	193	185	4 x 19	145	263	132	13 kg
FM080F-SZ	80	3	260	200	200	8 x 19	160	270	140	15 kg
FM100F-SZ	100	4	262	202	230	8 x 19	180	272	155	18 kg
FM125F-SZ	125	5	314	209	255	8 x 19	210	279	167	24 kg
FM150F-SZ	150	6	334	219	285	8 x 23	240	289	182	30 kg

## Further documentation

- Installation instructions