

Characterised control valve with sensor-operated flow control, 2-way, Flange, PN 16 (EPIV)

- Nominal voltage AC/DC 24 V
- Control modulating, communicative
- For closed chilled and hot water systems
- For modulating control of air-handling and heating systems on the water side
- Communication via Belimo MP-Bus or conventional control
- Conversion of active sensor signals and switching contacts

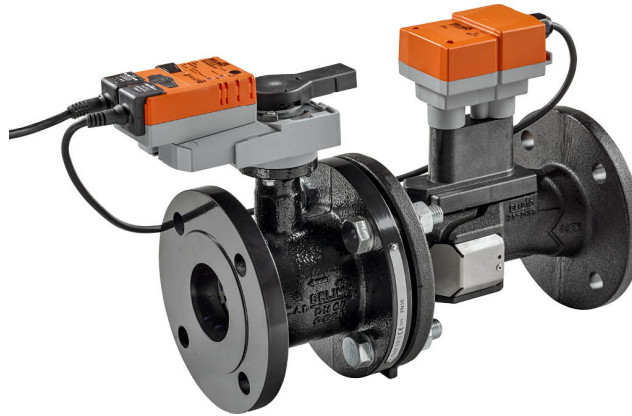

Type Overview

Type	DN	V'nom [l/s]	V'nom [l/min]	V'nom [m³/h]	Kvs theor. [m³/h]	PN
EP065F+MP	65	8	480	28.8	50	16
EP080F+MP	80	11	660	39.6	75	16
EP100F+MP	100	20	1200	72	127	16
EP125F+MP	125	31	1860	111.6	195	16
EP150F+MP	150	45	2700	162	254	16

Kvs theor.: theoretical Kvs value for pressure drop calculation

Technical data

Electrical data	Nominal voltage	AC/DC 24 V
	Nominal voltage frequency	50/60 Hz
	Nominal voltage range	AC 19.2...28.8 V / DC 21.6...28.8 V
	Power consumption in operation	6 W (DN 65, 80) 9 W (DN 100, 125, 150)
	Power consumption in rest position	4.5 W (DN 65, 80) 6 W (DN 100, 125, 150)
	Power consumption for wire sizing	10 VA (DN 65, 80) 12 VA (DN 100, 125, 150)
	Connection supply / control	Cable 1 m, 4x 0.75 mm ²
	Parallel operation	Yes (note the performance data)
	Data bus communication	Communicative control
Number of nodes		MP-Bus max. 8
Functional data	Operating range Y	2...10 V
	Input impedance	100 kΩ
	Operating range Y variable	Start point 0.5...24 V End point 8.5...32 V
	Operating modes optional	Modulating (DC 0...32 V)
	Position feedback U	2...10 V
	Position feedback U note	Max. 1 mA
	Position feedback U variable	Start point 0.5...8 V End point 2...10 V
	Sound power level Motor	45 dB(A)
	V'max adjustable	30...100% of V'nom
	Control accuracy	±5% (of 25...100% V'nom) @ 20°C / Glycol 0% vol.

Technical data

Functional data	Control accuracy note	±10% (of 25...100% V'nom) @ -10...120°C / Glycol 0...50% vol.
	Min. controllable flow	1% of V'nom
	Fluid	Chilled and hot water, water with glycol up to max. 50% vol.
	Fluid temperature	-10...120°C [14...248°F]
	Close-off pressure Δps	690 kPa
	Differential pressure Δpmax	340kPa
	Flow characteristic	equal percentage (VDI/VDE 2173), optimised in the opening range
	Flow characteristic note	switchable to linear (VDI/VDE 2173)
	Leakage rate	air-bubble tight, leakage rate A (EN 12266-1)
	Pipe connection	Flange according to EN 1092-2
	Installation orientation	upright to horizontal (in relation to the stem)
	Servicing	maintenance-free
	Manual override	with push-button, can be locked
	Flow measurement	Measuring principle
Measuring accuracy flow		±2% (of 25...100% V'nom) @ 20°C / glycol 0% vol.
Measuring accuracy flow note		±6% (of 25...100% V'nom) @ -10...120°C / glycol 0...50% vol.
Min. flow measurement		0.5% of V'nom
Safety data	Protection class IEC/EN	III, Safety Extra-Low Voltage (SELV)
	Degree of protection IEC/EN	IP54
	Pressure equipment directive	CE according to 2014/68/EU
	EMC	CE according to 2014/30/EU
	Type of action	Type 1
	Rated impulse voltage supply / control	0.8 kV
	Pollution degree	3
	Ambient humidity	Max. 95% RH, non-condensing
	Ambient temperature	-30...50°C [-22...122°F]
Storage temperature	-20...80°C [-4...176°F]	
Materials	Valve body	EN-GJL-250 (GG 25)
	Flow measuring pipe	EN-GJL-250 (GG 25), with protective paint
	Closing element	Stainless steel AISI 316
	Spindle	Stainless steel AISI 304
	Spindle seal	EPDM
	Seat	PTFE, O-ring Viton

Safety notes



- This device has been designed for use in stationary heating, ventilation and air-conditioning systems and must not be used outside the specified field of application, especially in aircraft or in any other airborne means of transport.
- Outdoor application: only possible in case that no (sea) water, snow, ice, insolation or aggressive gases interfere directly with the device and that it is ensured that the ambient conditions remain within the thresholds according to the data sheet at any time.
- Only authorised specialists may carry out installation. All applicable legal or institutional installation regulations must be complied with during installation.
- The device contains electrical and electronic components and must not be disposed of as household refuse. All locally valid regulations and requirements must be observed.

Product features

Operating mode The HVAC performance device is comprised of three components: characterised control valve (CCV), measuring pipe with flow sensor and the actuator itself. The adjusted maximum flow ($V'max$) is assigned to the maximum control signal (typically 10 V / 100%). The HVAC performance device can be controlled via communicative or analogue signals. The fluid is detected by the sensor in the measuring pipe and is applied as the flow value. The measured value is balanced with the setpoint. The actuator corrects the deviation by changing the valve position. The angle of rotation α varies according to the differential pressure through the control element (see flow curves).

Flow rate curves

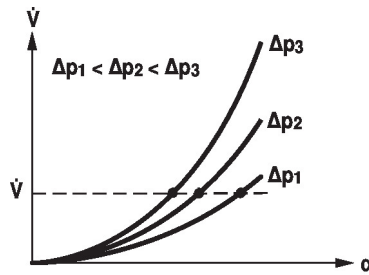

Transmission behaviour HE Heat exchanger transmission behaviour

Depending on the construction, temperature spread, fluid characteristics and hydronic circuit, the power Q is not proportional to the water volumetric flow V' (Curve 1). With the classical type of temperature control, an attempt is made to maintain the control signal Y proportional to the power Q (Curve 2). This is achieved by means of an equal-percentage flow characteristic (Curve 3).

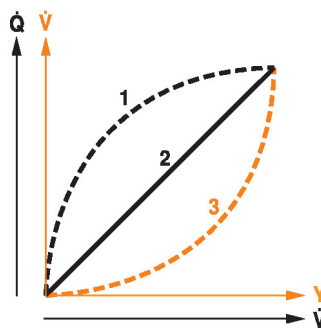

Control characteristics The fluid velocity is measured in the measuring component (sensor electronics) and converted to a flow rate signal.

The control signal Y corresponds to the power Q via the exchanger, the volumetric flow is regulated in the EPIV. The control signal Y is converted into an equal-percentage characteristic curve and provided with the V'max value as the new reference variable w. The momentary control deviation forms the control signal Y1 for the actuator.

The specially configured control parameters in connection with the precise flow rate sensor ensure a stable quality of control. They are however not suitable for rapid control processes, i.e. for domestic water control. U5 displays the measured flow as voltage (factory setting).

Parametrising V'max with ZTH EU:

U5 refers to the respective V'nom, i.e. if V'max is e.g. 50% of V'nom, then Y = 10 V, U5 = 5 V.

Parametrising V'max with PC-Tool:

In the PC-Tool, the maximum flow rate to which U5 refers can be set individually. If V'max is changed (e.g. to 70% V'nom), the U5 flow range is also automatically changed to the same value (e.g. 70% V'nom: U5 = 10 V). This adjustment can be reversed by entering a value manually (U5 flow range = 100%: U5 refers to V'nom).

As an alternative, U5 can be used for displaying the valve opening angle.

1. Standard equal percentage V'max = V'nom / 2. effect V'max < V'nom

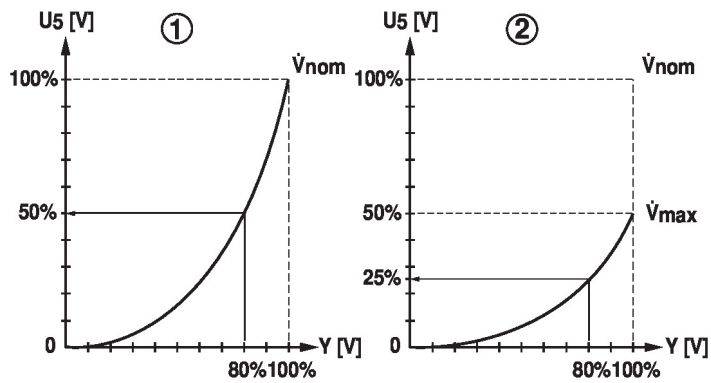

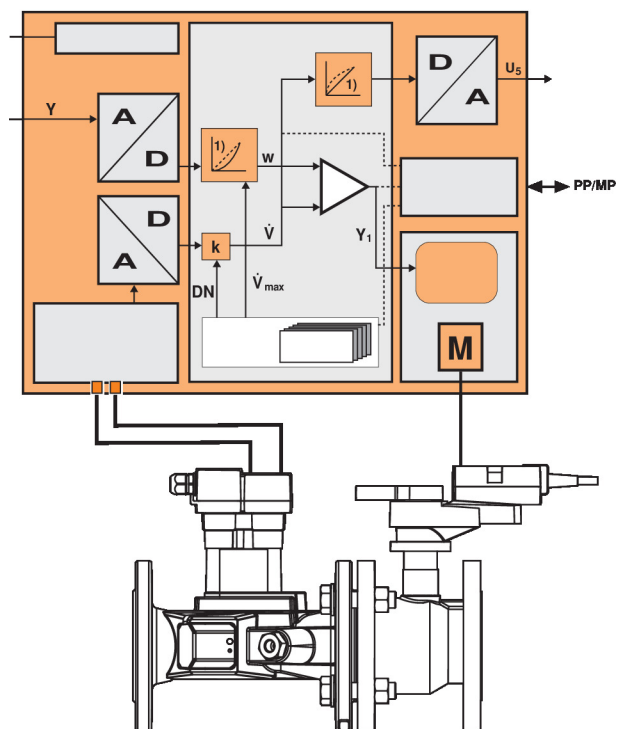

Flow control

V_{nom} is the maximum possible flow.

V_{max} is the maximum flow rate which has been set with the highest control signal. V_{max} can be set between 30% and 100% of V_{nom}.

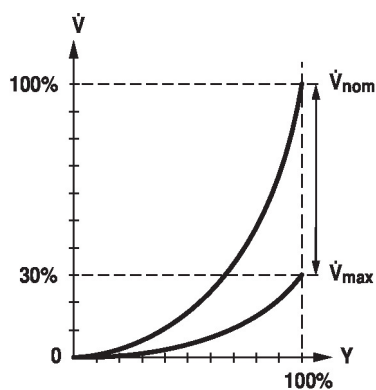

Product features

Creep flow suppression Given the very low flow speed in the opening point, this can no longer be measured by the sensor within the required tolerance. This range is overridden electronically.

Opening valve
The valve remains closed until the flow required by the control signal DDC corresponds to 1% of V'nom. The control along the flow characteristic is active after this value has been exceeded.

Closing valve
The control along the flow characteristic is active up to the required flow rate of 1% of V'nom. Once the level falls below this value, the flow rate is maintained at 1% of V'nom. If the level falls below the flow rate of 0.5% of V'nom required by the control signal DDC, then the valve will close.

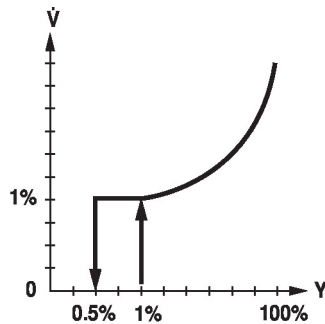

Converter for sensors Connection option for a sensor (active sensor or switching contact). The MP actuator serves as an analogue/digital converter for the transmission of the sensor signal via MP-Bus to the higher level system.

Configurable actuators The factory settings cover the most common applications. Single parameters can be modified with Belimo Assistant 2 or ZTH EU.

Control signal inversion This can be inverted in cases of control with an analogue control signal. The inversion causes the reversal of the standard behaviour, i.e. at a control signal of 0%, regulation is to V'max, and the valve is closed at a control signal of 100%.

Hydronic balancing With the Belimo tools, the maximum flow rate (equivalent to 100% requirement) can be adjusted on-site, simply and reliably, in a few steps. If the device is integrated in the management system, then the balancing can be handled directly by the management system.

Manual override Manual override with push-button possible (the gear train is disengaged for as long as the button is pressed or remains locked).

High functional safety The actuator is overload protected, requires no limit switches and automatically stops when the end stop is reached.

Accessories

Tools	Description	Type
	Service tool, with ZIP-USB function, for parametrisable and communicative Belimo actuators, VAV controller and HVAC performance devices	ZTH EU
	Service tool for wired and wireless setup, on-site operation, and troubleshooting.	Belimo Assistant 2
	Adapter for Service-Tool ZTH	MFT-C
	Connecting cable 5 m, A: RJ11 6/4 ZTH EU, B: 6-pin for connection to service socket	ZK1-GEN
	Connecting cable 5 m, A: RJ11 6/4 ZTH EU, B: free wire end for connection to MP/PP terminal	ZK2-GEN

Accessories

Electrical accessories	Description	Type
	Stem heater flange F05 (30 W)	ZR24-F05
	MP-Bus power supply for MP actuators	ZN230-24MP
Gateways	Description	Type
	Gateway MP to BACnet MS/TP	UK24BAC
	Gateway MP to Modbus RTU	UK24MOD

Electrical installation



Supply from isolating transformer.

Parallel connection of other actuators possible. Observe the performance data.

Wire colours:

- 1 = black
- 2 = red
- 3 = white
- 5 = orange

AC/DC 24 V, modulating

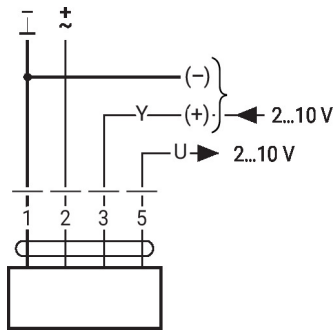

MP-Bus

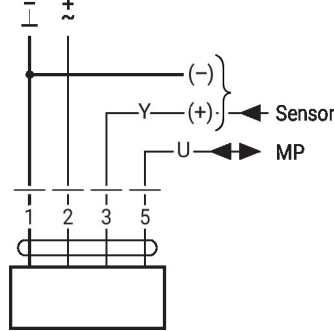

Converter for sensors

Connection of external switching contact

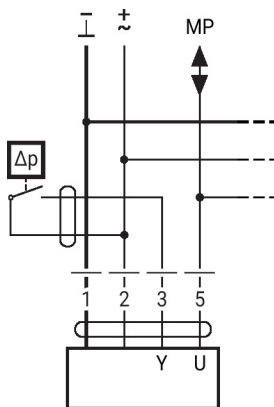

- Switching current 16 mA @ 24 V
- Start point of the operating range must be parametrised on the MP actuator as ≥ 0.5 V

Connection of active sensors

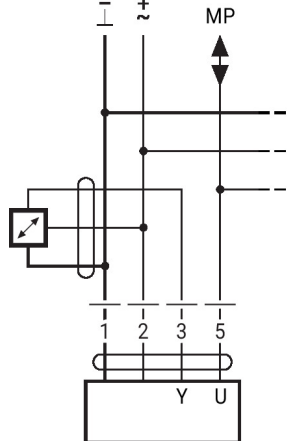

- Supply AC/DC 24 V
- Output signal 0...10 V (max. 0...32 V)
- Resolution 30 mV

Further electrical installations

Functions with specific parameters (parametrisation necessary)

Override control and limiting with AC 24 V with relay contacts

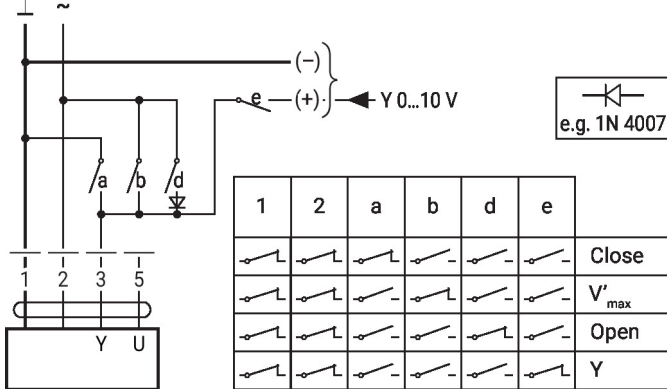

Override control and limiting with DC 24 V with relay contacts

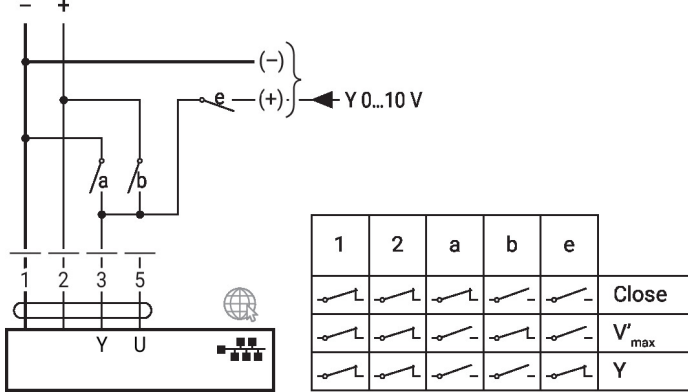

Control 3-point

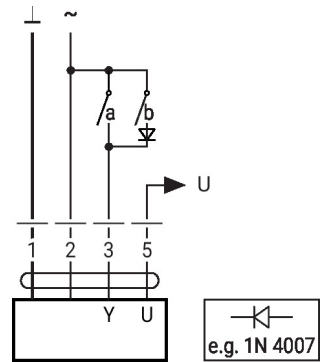

Operating controls and indicators

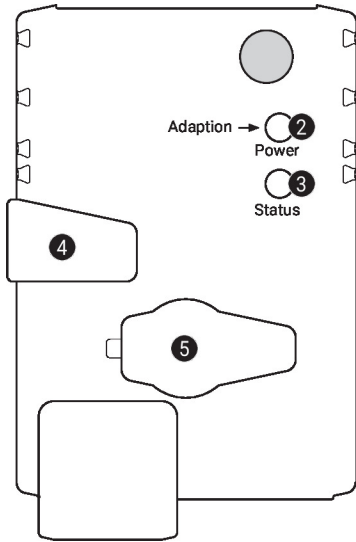

2 Push-button and LED display green

- Off: No power supply or malfunction
- On: In operation
- Press button: Triggers angle of rotation adaptation, followed by standard mode

3 Push-button and LED display yellow

- Off: Standard mode
- On: Adaptation or synchronisation process active
- Flickering: MP-Bus communication active
- Press button: Confirmation of the addressing

4 Manual override button

- Press button: Gear train disengages, motor stops, manual override possible
- Release button: Gear train engages, standard mode

5 Service plug

For connecting parametrisation and service tools

Check power supply connection

- 2** Off and **3** On Possible wiring error in power supply

Installation notes

Permissible installation orientation

The ball valve can be installed upright to horizontal. The ball valve may not be installed in a hanging position, i.e. with the spindle pointing downwards.

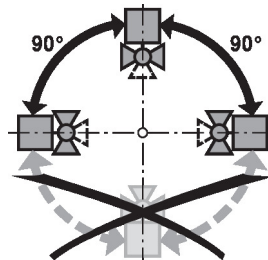

Installation location in return

Installation in the return is recommended.

Water quality requirements

The water quality requirements specified in VDI 2035 must be adhered to.

Belimo valves are regulating devices. For the valves to function correctly in the long term, they must be kept free from particle debris (e.g. welding beads during installation work). The installation of a suitable strainer is recommended.

The water must exhibit a conductivity $\geq 20 \mu\text{S}/\text{cm}$ during operation for correct functioning. It should be noted that, under normal circumstances, even filling water with a lower conductivity will experience an elevation of its conductivity to above the minimum required value during filling and that the system can thus be put into operation.

Elevation of conductivity during filling caused by:

- untreated residual water from pressure test or pre-rinsing
- metal salts (e.g. surface rust) dissolved out of the raw material

Installation notes

Spindle heater In cold water applications and warm humid ambient air, condensation can be caused in the actuators. This can lead to corrosion in the gear train of the actuator and a breakdown of the actuator. In such applications, the use of a spindle heater is recommended.
The spindle heater must only be activated when the system is in operation because it does not have a temperature controller.

Servicing Ball valves, rotary actuators and sensors are maintenance-free.
Before any service work on the control element is carried out, it is essential to isolate the rotary actuator from the power supply (by unplugging the electrical cable if necessary). Any pumps in the part of the piping system concerned must also be switched off and the appropriate slide valves closed (allow all components to cool down first if necessary and always reduce the system pressure to ambient pressure level).
The system must not be returned to service until the ball valve and the rotary actuator have been correctly reassembled in accordance with the instructions and the pipeline has been refilled by professionally trained personnel.

Flow direction The direction of flow, specified by an arrow on the housing, is to be complied with, since otherwise the flow rate will be measured incorrectly.

Inlet section In order to achieve the specified measuring accuracy, a flow-calming section or inflow section in the direction of the flow is to be provided upstream from the flow sensor. Its dimensions should be at least 5x DN.

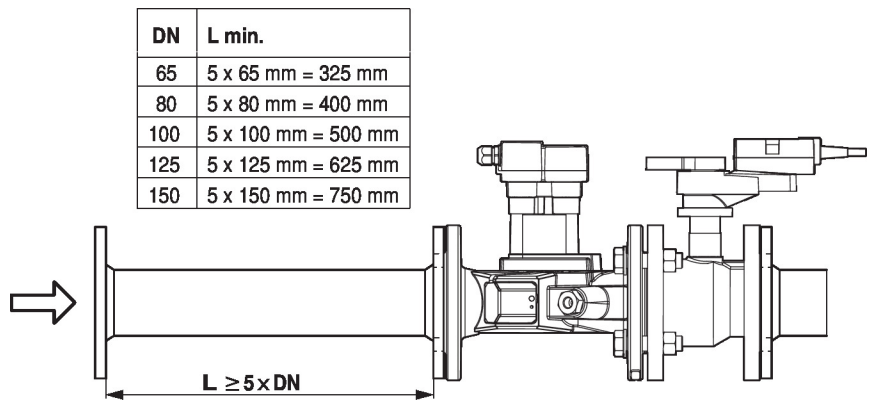

Split installation The valve-actuator combination may be mounted separately from the flow sensor. The direction of flow of both components must be observed.

General notes

Minimum differential pressure (pressure drop)

The minimum required differential pressure (pressure drop through the valve) for achieving the desired volumetric flow V'max can be calculated with the aid of the theoretical Kvs value (see type overview) and the below-mentioned formula. The calculated value is dependent on the required maximum volumetric flow V'max. Higher differential pressures are compensated for automatically by the valve.

Formula

$$\Delta p_{min} = 100 \times \left(\frac{V'_{max}}{K_{vs \text{ theor.}}} \right)^2$$

$\Delta p_{min}: \text{kPa}$
 $V'_{max}: \text{m}^3/\text{h}$
 $K_{vs \text{ theor.}}: \text{m}^3/\text{h}$

Example (DN 100 with the desired maximum flow rate = 50% V'nom)

EP100F+MP

$K_{vs \text{ theor.}} = 127 \text{ m}^3/\text{h}$

$V'_{nom} = 1200 \text{ l}/\text{min}$

$50\% * 1200 \text{ l}/\text{min} = 600 \text{ l}/\text{min} = 36 \text{ m}^3/\text{h}$

$$\Delta p_{min} = 100 \times \left(\frac{V'_{max}}{K_{vs \text{ theor.}}} \right)^2 = 100 \times \left(\frac{36 \text{ m}^3/\text{h}}{127 \text{ m}^3/\text{h}} \right)^2 = 8 \text{ kPa}$$

Behaviour in case of sensor failure

In case of a flow sensor error, the EPIV will switch from flow control to position control. Once the error disappears, the EPIV will switch back to the normal control setting.

Service

Tools connection

The device can be parametrised by ZTH EU via the service socket.

For an extended parametrisation, Belimo Assistant 2 can be connected.

Connection ZTH EU / Belimo Assistant 2

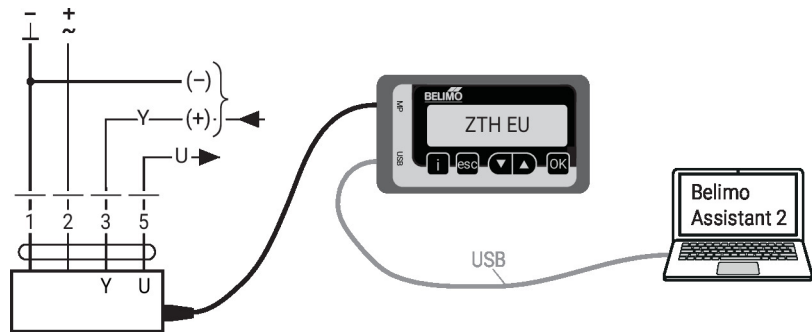

Dimensions

Dimensional drawings

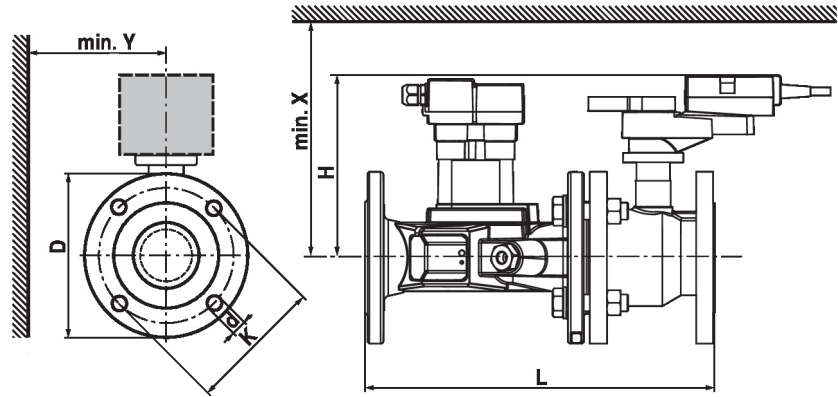

If $Y < 180$ mm, the extension of the hand crank must be demounted as necessary.

Type	DN	L [mm]	H [mm]	D [mm]	d [mm]	K [mm]	X [mm]	Y [mm]	 kg
EP065F+MP	65	379	197	185	4 x 19	145	220	150	25
EP080F+MP	80	430	197	200	8 x 19	160	220	160	31
EP100F+MP	100	474	221	229	8 x 19	180	240	175	45
EP125F+MP	125	579	240	252	8 x 19	210	260	190	61
EP150F+MP	150	651	240	282	8 x 23	240	260	200	73

Further documentation

- Overview MP Cooperation Partners
- Tool connections
- Introduction to MP-Bus Technology
- General notes for project planning
- Quick Guide – Belimo Assistant 2