

Butterfly valve with Lug types

- For open and closed cold and warm water systems
- For switching heat generators or cooling machines on/off

Type overview

Type	DN	Kvmax [m ³ /h]	Kvs [m ³ /h]	PN
D6350BL	350	10300	3010	16
D6400BL	400	14200	4140	16
D6450BL	450	18800	5490	16
D6500BL	500	24100	7060	16
D6600BL	600	37300	10900	16

Technical data

Functional data	Fluid	Cold and warm water, water with glycol up to max. 50% vol.	
	Fluid temperature	-10...120°C [14...248°F]	
	Flow characteristic	0...100% opening angle: S-form 0...60% opening angle: equal percentage (VDI/VDE 2173) modified equal-percentage	
	Leakage rate	tight, leakage rate A (EN 12266-1)	
	Angle of rotation	90°	
	Pipe connection	Flange according to ISO 7005-1 according to EN 1092-1 according to ISO 7005-2 according to EN 1092-2	
	Installation orientation	upright to horizontal (in relation to the stem)	
	Servicing	maintenance-free	
	Materials	Valve body	EN-GJS-400-15 (GGG 40)
		Body finish	polyester powder coated
Closing element		Stainless steel AISI 304 (1.4301)	
Spindle		Stainless steel AISI 630 (1.4542)	
Spindle seal		EPDM O-ring	
Spindle bearing		RPTFE	
Seat		EPDM	

Safety notes



- The valve has been designed for use in stationary heating, ventilation and air-conditioning systems and must not be used outside the specified field of application, especially in aircraft or in any other airborne means of transport.
- Only authorised specialists may carry out installation. All applicable legal or institutional installation regulations must be complied with during installation.
- The valve does not contain any parts that can be replaced or repaired by the user.
- The valve may not be disposed of as household refuse. All locally valid regulations and requirements must be observed.
- When determining the flow rate characteristic of controlled devices, the recognised directives must be observed.
- The damper must be opened and closed slowly in order to avoid hydronic shocks in the pipe system.

Product features

- Operating mode** The butterfly valve is opened or closed completely by an open/close rotary actuator. Continuous rotary actuators are connected by a commercially available controller and move the valve to any position desired. The valve disk made of stainless steel is pressed into the soft-sealing EPDM seat by a rotary movement and ensures leakage rate A (tight). The pressure losses are slight in the open position and the kv value is at a maximum.
- Manual override** Manual throttling or isolation can be carried out with a worm gear (see «Accessories»). The worm gear with position indication is steplessly adjustable (self-locking).

Accessories

Mechanical accessories	Description	Type
	Worm gear for butterfly valves DN 350	ZD6N-S350
	Worm gear for butterfly valves DN 400	ZD6N-S400
	Worm gear for butterfly valves DN 450	ZD6N-S450
	Worm gear for butterfly valves DN 500	ZD6N-S500
	Worm gear for butterfly valves DN 600	ZD6N-S600

Installation notes

Permissible installation orientation The butterfly valves may be mounted upright to horizontal. The butterfly valves may not be installed in a hanging position i.e. with the spindle pointing downwards.

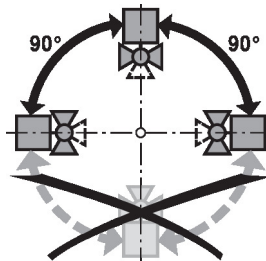

Water quality requirements The water quality requirements specified in VDI 2035 must be adhered to.

Installation notes

Servicing Butterfly valves and rotary actuators are maintenance-free.

Before any service work on the control element is carried out, it is essential to isolate the rotary actuator from the power supply (by unplugging the electrical cable if necessary). Any pumps in the part of the piping system concerned must also be switched off and the appropriate slide valves closed (allow all components to cool down first if necessary and always reduce the system pressure to ambient pressure level).

The system must not be returned to service until the butterfly valve and the rotary actuator have been reassembled correctly in accordance with the instructions and the pipeline has been refilled by professionally trained personnel.

To avoid a torque increase during off season shut down, exercise the butterfly valve (full open and close) at least once a month.

Flow setting The Belimo butterfly valves have an approximate equal percentage characteristic curve between 0...60% opening angle.

The following table shows the respective kv values in relation to the opening angle (%).

		10%	20%	30%	40%	50%	60%	70%	80%	90%	100%
DN 350	kv (m3/h)	5	240	520	1050	1860	3010	4640	6880	9470	10300
DN 400	kv (m3/h)	6	320	720	1450	2560	4140	6380	9460	13030	14200
DN 450	kv (m3/h)	9	430	950	1920	3400	5490	8460	12530	17250	18800
DN 500	kv (m3/h)	11	550	1220	2460	4370	7060	10870	16110	22190	24100
DN 600	kv (m3/h)	17	850	1880	3800	6740	10900	16800	24890	34280	37300



Dimensions

Dimensional drawings

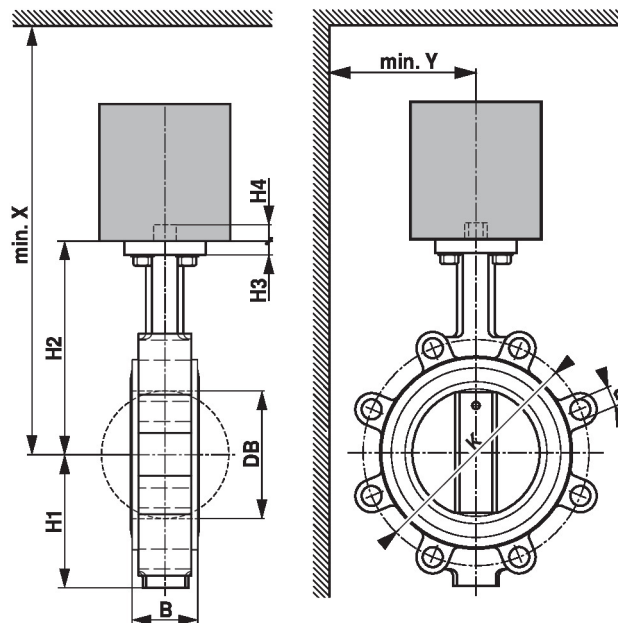

Dimensions

Type	DN	B [mm]	DB [mm]	H1 [mm]	H2 [mm]	H3 [mm]	H4 [mm]	d (PN16)	K (PN16) [mm]	X [mm]	Y [mm]	Weight
D6350BL	350	78	332	278	368	15	24	16 x M24	470	1220	400	45 kg
D6400BL	400	102	388	307	399	20	48	16 x M27	525	1300	500	92 kg
D6450BL	450	114	439	331	426	20	48	20 x M27	585	1300	500	110 kg
D6500BL	500	127	482	361	481	22	48	20 x M30	650	1700	600	150 kg
D6600BL	600	154	586	456	563	22	48	20 x M33	770	1800	700	240 kg

Further documentation

- The complete product range for water applications
- Data sheets for actuators
- Installation instructions for actuators and/or butterfly valves
- General notes for project planning