

Pressure-independent globe valve, 2-way,
Flange, PN 25

- For closed water circuits (pH >7)
- For district heating



Type overview

Type	DN	V'nom [m ³ /h]	Kvs theor. [m ³ /h]	Stroke	PN	Sv min.
EXT-H615XP-125	15	1.3	2.5	10 mm	25	20
EXT-H615XP-200	15	1.8	4	10 mm	25	20
EXT-H625XP-315	25	3	6.3	11 mm	25	22
EXT-H625XP-400	25	4	8	11 mm	25	21
EXT-H632XP-650	32	6.5	12.5	13 mm	25	20
EXT-H640XP-900	40	11	20	13 mm	25	23
EXT-H650XP-1500	50	16	32	13 mm	25	22
EXT-H665XP-2500	65	28	50	15 mm	25	22
EXT-H680XP-3600	80	40	80	18 mm	25	20
EXT-H6100XP-6500	100	60	125	21 mm	25	24
EXT-H6125XP-8000	125	80	180	21 mm	25	24

Kvs theor.: theoretical Kvs value for pressure drop calculation

Technical data

Functional data	V'max adjustable	20...100% of V'nom
	Fluid	Hot water, water quality according to VDI 2035
	Fluid temperature	5...140°C [41...284°F]
	Differential pressure Δp_{max}	1500 kPa
	Differential pressure across the control valve	20 kPa
	Flow characteristic	equal percentage
	Leakage rate	max. 0.02% of the Kvs value (DN 15, 25) max. 0.05% of the Kvs value (DN 32, 40, 50, 65, 80, 100, 125)
	Closing point	Bottom (▼)
	Cavitation factor (Z)	DN 15: 0.6 DN 25/32: 0.55 DN 40/50: 0.5 DN 65: 0.45 DN 80: 0.4 DN 100/125: 0.35
	Pipe connection	Flange according to EN 1092-2
	Installation orientation	upright to $\pm 45^\circ$ (in relation to the stem)
	Servicing	maintenance-free
	Materials	Valve body
Body finish		with protective paint
Closing element		WN1.4057

Technical data

Materials	Spindle	WN1.4404
	Spindle seal	FPM, EPDM (ISO 1629)
	Seat	WN1.4021
	Diaphragm	EPDM
	Spring	WN1.4310
	Diaphragm	EPDM

Safety notes



- The valve has been designed for use in stationary heating systems and must not be used outside the specified field of application, especially in aircraft or in any other airborne means of transport.
- Only authorised specialists may carry out installation. All applicable legal or institutional installation regulations must be complied with during installation.
- The valve may not be disposed of as household refuse. All locally valid regulations and requirements must be observed.
- When determining the flow rate characteristic of controlled devices, the recognised directives must be observed.

Product features

Operating mode	The mechanical pressure-independent globe valve consists of a mechanical differential pressure controller and a control valve which is motorised with a Belimo actuator. The mechanically set maximum flow (V_{max}) is assigned to the control signal DDC (typically 10 V / 100%). The differential pressure controller compensates for pressure fluctuations and keeps the differential pressure across the control valve constant. The flow can be controlled via the control signal DDC. However, it is important to note that correct flow control requires a minimum differential pressure across the valve.
Flow characteristic	An equal percentage flow characteristic is produced by the profile of the valve cone.
Fluid velocity	Standard values for low-noise operation in HVAC systems are fluid velocities of 1...2 m/s. At fluid velocities above 2 m/s, further flow effects like noise as well as cavitation can occur. This can reduce the service life of a valve depending on the situation.
Minimum differential pressure	To maintain adequate flow control, it is essential that the differential pressure remains above a certain threshold. This threshold is calculated as follows: $(V/Kvs)^2 + 0.2 \text{ bar}$ (V = flow rate (m^3/h)). It is important to maintain the differential pressure above this calculated value to guarantee optimal flow control.

Installation notes

Permissible installation orientation The globe valve may be mounted upright to $\pm 45^\circ$. It is not permissible to mount the globe valves with the stem pointing sideways or downwards.

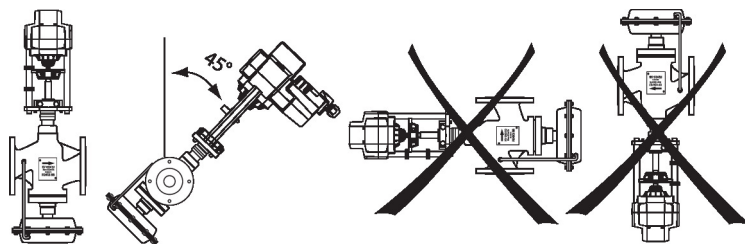

Water quality requirements The water quality requirements specified in VDI 2035 must be adhered to. Belimo valves are regulating devices. For the valves to function correctly in the long term, they must be kept free from particle debris (e.g. welding beads during installation work). The installation of a suitable strainer is recommended.

Servicing Globe valves and globe valve actuators are maintenance-free. Before any service work on the control element is carried out, it is essential to isolate the globe valve actuator from the power supply (by unplugging the electrical cables if necessary). Any pumps in the part of the piping system concerned must also be switched off and the appropriate slide valves closed (allow all components to cool down first if necessary and always reduce the system pressure to ambient pressure level). The system must not be returned to service until the globe valve and the globe valve actuator have been reassembled correctly in accordance with the instructions and the pipeline has been refilled by professionally trained personnel.

Flow direction The direction of flow, specified by an arrow on the housing, is to be complied with, since otherwise the valve could become damaged.

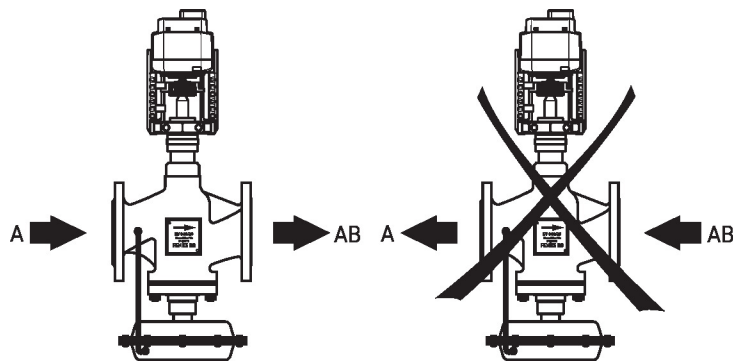

Flow setting The valve maximum flow (V'_{max}) is an adjustable parameter that can be controlled by rotating the setting ring located on the valve neck. The valve offers the ability to adjust the flow rate via a counterclockwise rotation from its minimum position.

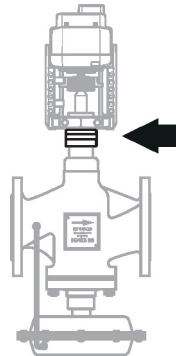

Rotate the setting ring counterclockwise from its lowest position to increase the flow rate. The relationship between the setting ring rotation and the resulting flow is depicted by the flow setting curves provided in the notes for project planning EXT-H6..

Installation notes

Pressure/temperature diagram The maximum operational pressure is directly correlated to the temperature of the circulating water.

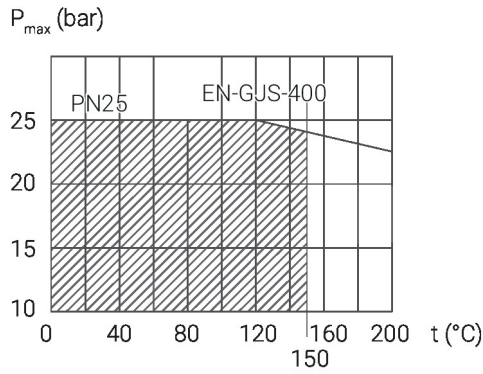
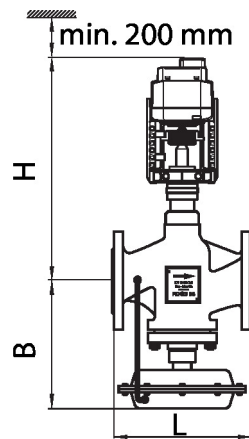
Dimensions
Dimensional drawings

Type	DN	B [mm]	L [mm]	H [mm]	Weight
EXT-H615XP-125	15	170	130	245	9.5 kg
EXT-H615XP-200	15	170	130	245	9.5 kg
EXT-H625XP-315	25	205	160	295	12.5 kg
EXT-H625XP-400	25	205	160	295	12.5 kg
EXT-H632XP-650	32	210	180	300	15.5 kg
EXT-H640XP-900	40	220	200	300	17.5 kg
EXT-H650XP-1500	50	235	230	305	24.5 kg
EXT-H665XP-2500	65	360	290	435	46 kg
EXT-H680XP-3600	80	400	310	450	55 kg
EXT-H6100XP-6500	100	425	350	465	78 kg
EXT-H6125XP-8000	125	480	400	480	93 kg