

Butterfly Valve with ANSI Class 150 Lug types

- Disc 316 stainless steel
- Bubble tight shut-off
- Teflon seat
- Valve face-to-face dimensions comply with API 609 & MSS-SP-67
- For use with dead-end service
- Completely assembled and tested, ready for installation



5-year warranty

Type overview

Type	DN
F6100-150SHP	100

Technical data

Functional data	Valve size [mm]	4" [100]
	Fluid	chilled or hot water, up to 60% glycol, steam
	Fluid Temp Range (water)	-22...400°F [-30...204°C]
	Body Pressure Rating	ANSI Class 150
	Close-off pressure Δps	285 psi
	Flow characteristic	modified equal percentage, unidirectional
	Pipe connection	Flange for use with ASME/ANSI class 150
	Servicing	maintenance-free
	Flow Pattern	2-way
	Leakage rate	0%
	Controllable flow range	quarter turn, mechanically limited
	Cv	451
	Maximum Inlet Pressure (Steam)	50 psi
	Maximum Velocity	32 FPS
Lug threads	5/8-11 UNC	
Materials	Valve body	Carbon steel full lug (ASME B16.34)
	Stem	17-4 PH stainless steel
	Seat	RPTFE
	Bearing	glass backed PTFE
	Disc	316 stainless steel
Suitable actuators	Non Fail-Safe	PRB(X) GMB(X)
	Spring	2*AFB(X)
	Electrical fail-safe	PKRB(X) GKRB(X)

Safety notes

- **WARNING:** This product can expose you to lead which is known to the State of California to cause cancer and reproductive harm. For more information go to www.p65warnings.ca.gov

Product features

Flow/Mounting details

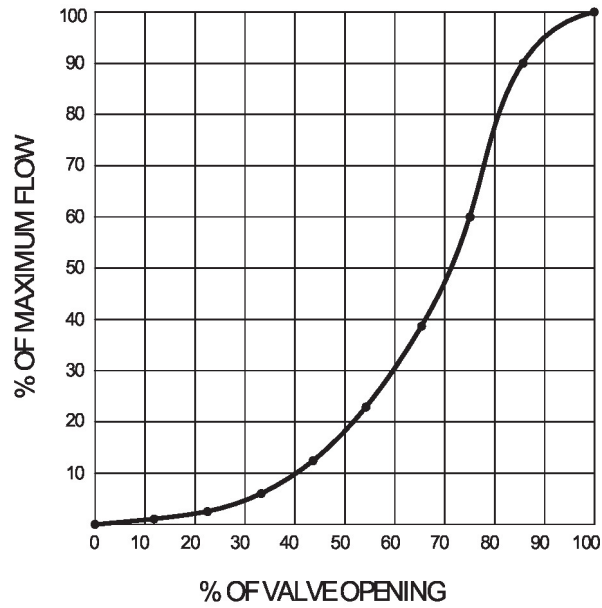

Dimensions

Type	DN	Weight
F6100-150SHP	100	10 lb [4.5 kg]

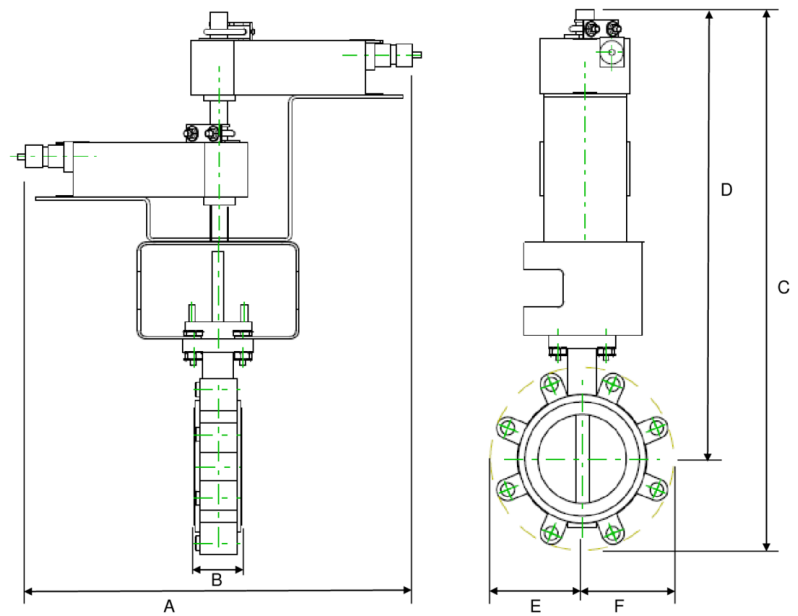

A	B	C	D	E	F	Number of Bolt Holes
18.0" [457]	2.1" [54]	24.0" [610]	20.5" [521]	4.3" [110]	4.3" [110]	8

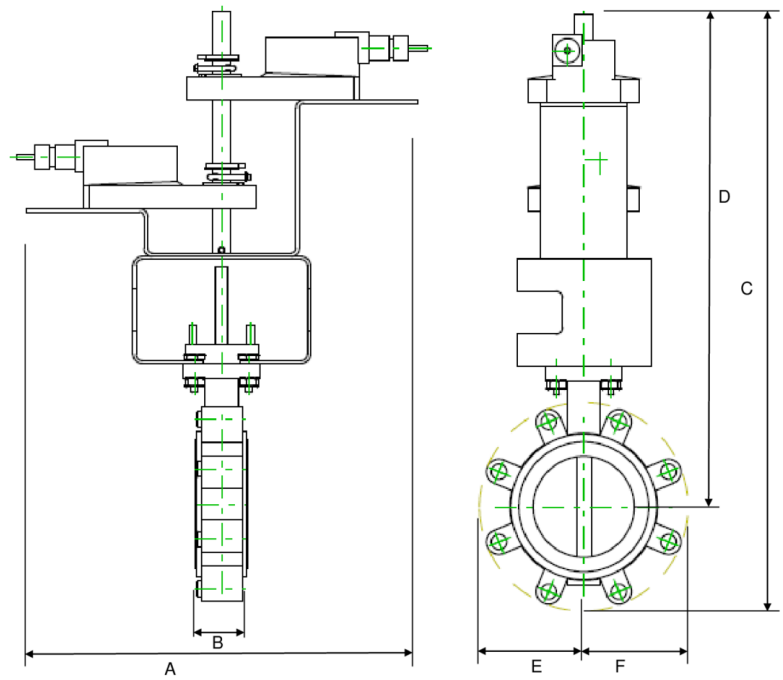

A	B	C	D	E	F	Number of Bolt Holes
18.9" [480]	2.2" [56]	24.3" [616]	20.1" [511]	4.3" [110]	4.3" [110]	8

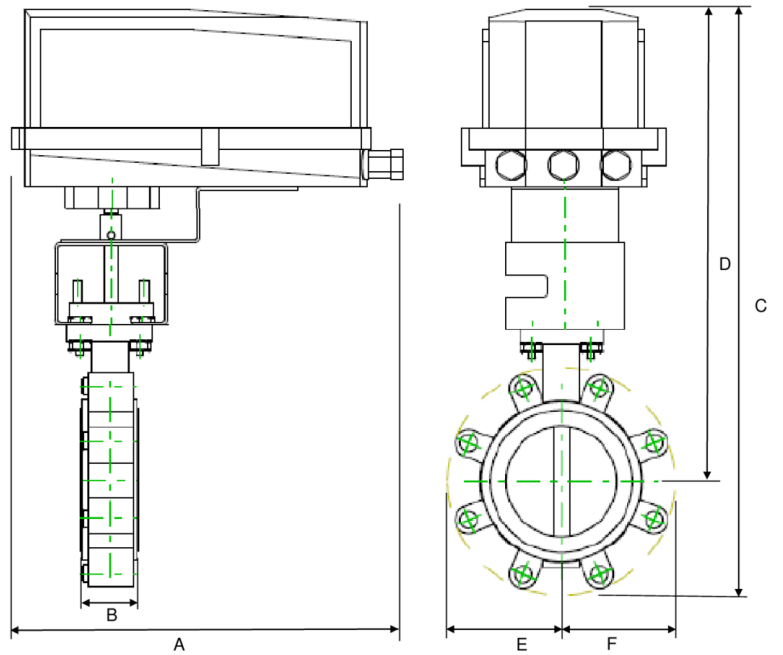

A	B	C	D	E	F	Number of Bolt Holes
15.3" [388]	2.2" [56]	18.7" [476]	14.8" [377]	3.9" [100]	3.9" [100]	8

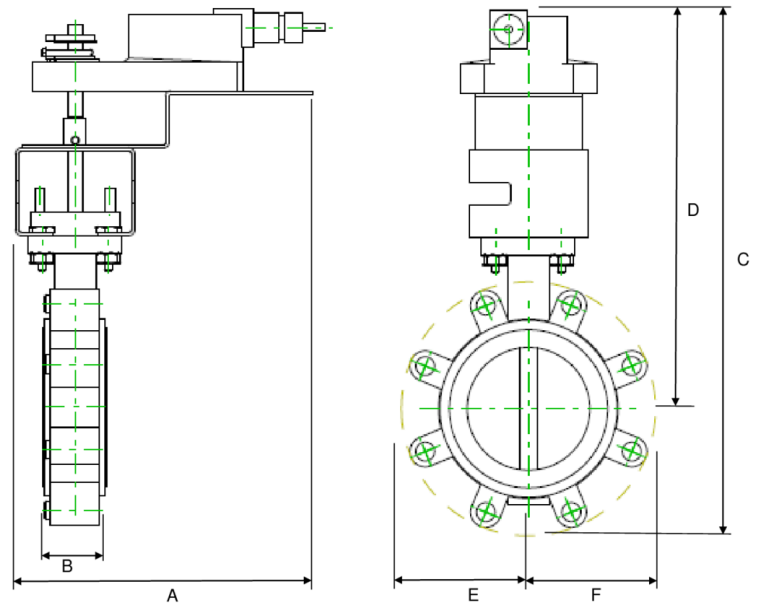

A	B	C	D	E	F	Number of Bolt Holes
10.9" [277]	2.2" [56]	20.3" [515]	15.5" [394]	4.9" [124]	4.9" [125]	8

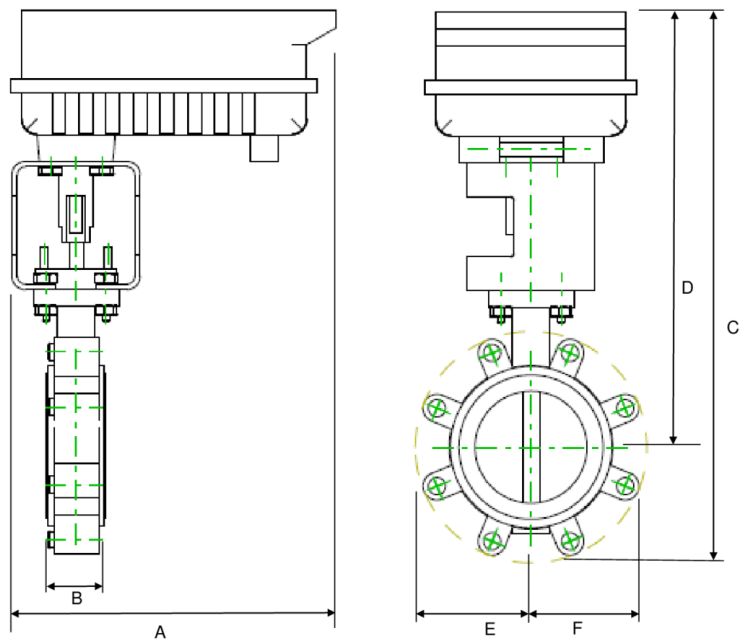

A	B	C	D	E	F	Number of Bolt Holes
9.1" [231]	2.2" [56]	17.2" [438]	13.3" [338]	3.9" [100]	3.9" [100]	8

Dimensions

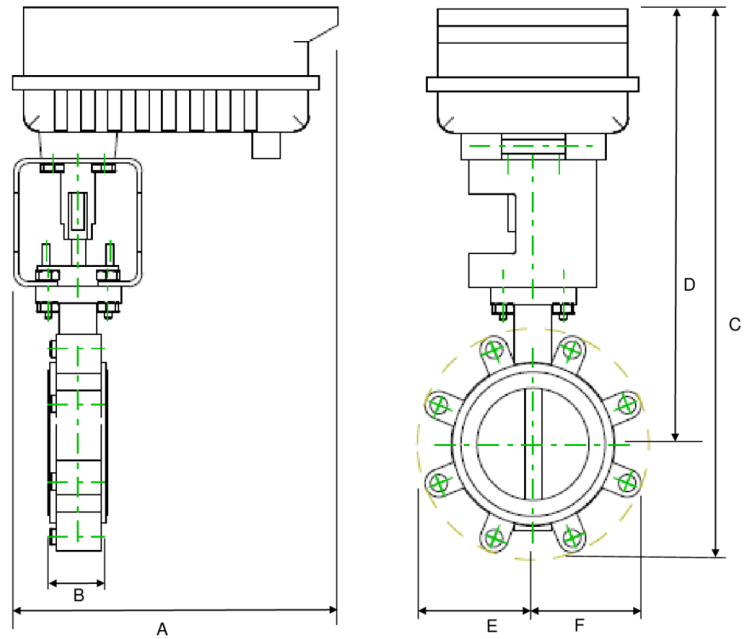

A	B	C	D	E	F	Number of Bolt Holes
14.1" [358]	2.2" [56]	24.9" [632]	19.6" [498]	5.4" [137]	5.4" [137]	8

MFT/programmable, Electrical fail-safe, 24 V



5-year warranty



Technical data

Electrical data	Nominal voltage	AC/DC 24 V
	Nominal voltage frequency	50/60 Hz
	Nominal voltage range	AC 19.2...28.8 V / DC 21.6...28.8 V
	Power consumption in operation	12 W
	Power consumption in rest position	3 W
	Transformer sizing	21 VA
	Electrical Connection	18 GA plenum cable, 1 m, 3 m, or 5 m with 1/2" NPT conduit connector, degree of protection NEMA 2 / IP54
Overload Protection	electronic throughout 0...95° rotation	
Functional data	Operating range Y	2...10 V
	Operating range Y note	4...20 mA w/ ZG-R01 (500 Ω, 1/4 W resistor)
	Input impedance	100 kΩ for 2...10 V (0.1 mA), 500 Ω for 4...20 mA, 1500 Ω for PWM, On/Off and Floating point
	Operating range Y variable	Start point 0.5...30 V End point 2.5...32 V
	Operating modes optional	variable (VDC, on/off, floating point)
	Position feedback U	2...10 V
	Position feedback U note	Max. 0.5 mA
	Position feedback U variable	VDC variable
	Bridging time (PF)	2 s
	Bridging time (PF) variable	0...10 s
	Pre-charging time	5...20 s
	Direction of motion motor	selectable with switch 0/1
	Direction of motion fail-safe	reversible with switch
	Manual override	external push button
	Angle of rotation	Max. 95°
	Angle of rotation note	adjustable with mechanical stop
	Running Time (Motor)	150 s / 90°
	Running time motor variable	95...150 s
	Running time fail-safe	<35 s
Noise level, motor	52 dB(A)	
Noise level, fail-safe	61 dB(A)	
Position indication	Mechanical, 30...65 mm stroke	
Safety data	Power source UL	Class 2 Supply

Technical data

Safety data	Degree of protection IEC/EN	IP54
	Degree of protection NEMA/UL	NEMA 2
	Enclosure	UL Enclosure Type 2
	Agency Listing	cULus acc. to UL60730-1A/-2-14, CAN/CSA E60730-1:02 CE acc. to 2014/30/EU and 2014/35/EU
	Quality Standard	ISO 9001
	UL 2043 Compliant	Suitable for use in air plenums per Section 300.22(C) of the NEC and Section 602 of the IMC
	Ambient humidity	Max. 95% RH, non-condensing
	Ambient temperature	-22...122°F [-30...50°C]
	Storage temperature	-40...176°F [-40...80°C]
	Servicing	maintenance-free
Weight	Weight	4.0 lb [1.8 kg]
Materials	Housing material	Galvanized steel and plastic housing

Footnotes †Rated Impulse Voltage 800V, Type of action 1.AA, Control Pollution Degree 3

Product features

Bridging time Power failures can be bridged up to a maximum of 10 s.

In the event of a power failure, the actuator will remain stationary in accordance with the set bridging time. If the power failure is greater than the set bridging time, the actuator will move into the selected fail-safe position.

The bridging time set at the factory is 2 s. It can be modified on site in operation by means of the Belimo service tool MFT-P.



Settings: The rotary knob must not be set to the "PROG FAIL-SAFE" position!

For retroactive adjustments of the bridging time with the Belimo service tool MFT-P or with the ZTH EU adjustment and diagnostic device only the values need to be entered.

Accessories

Electrical accessories	Description	Type
	Feedback potentiometer 140 Ω add-on, grey	P140A GR
	Feedback potentiometer 500 Ω add-on, grey	P500A GR
	Feedback potentiometer 1 kΩ add-on, grey	P1000A GR
	Feedback potentiometer 2.8 kΩ add-on, grey	P2800A GR
	Feedback potentiometer 5 kΩ add-on, grey	P5000A GR
	Feedback potentiometer 10 kΩ add-on, grey	P10000A GR
	Auxiliary switch 1x SPDT add-on	S1A
	Auxiliary switch 2x SPDT add-on	S2A
	Service tool, with ZIP-USB function, for programmable and communicative Belimo actuators, VAV controller and HVAC performance devices	ZTH US

Electrical installation
 **INSTALLATION NOTES**

-  Actuators with appliance cables are numbered.
-  Provide overload protection and disconnect as required.
-  Actuators may also be powered by DC 24 V.

Electrical installation

- ⚠️ Only connect common to negative (-) leg of control circuits.
- ⚠️ A 500 Ω resistor (ZG-R01) converts the 4...20 mA control signal to 2...10 V.
- ⚠️ Control signal may be pulsed from either the Hot (Source) or Common (Sink) 24 V line.
- ⚠️ For triac sink the Common connection from the actuator must be connected to the Hot connection of the controller. Position feedback cannot be used with a triac sink controller; the actuator internal common reference is not compatible.
- ⚠️ IN4004 or IN4007 diode. (IN4007 supplied, Belimo part number 40155).
- ⚠️ Actuators may be controlled in parallel. Current draw and input impedance must be observed.
- ⚠️ Master-Slave wiring required for piggy-back applications. Feedback from Master to control input(s) of Slave(s).

◆ Meets cULus requirements without the need of an electrical ground connection.

⚠️ **Warning! Live electrical components!**

During installation, testing, servicing and troubleshooting of this product, it may be necessary to work with live electrical components. Have a qualified licensed electrician or other individual who has been properly trained in handling live electrical components perform these tasks. Failure to follow all electrical safety precautions when exposed to live electrical components could result in death or serious injury.

Wiring diagrams

On/Off

24 VAC Transformer

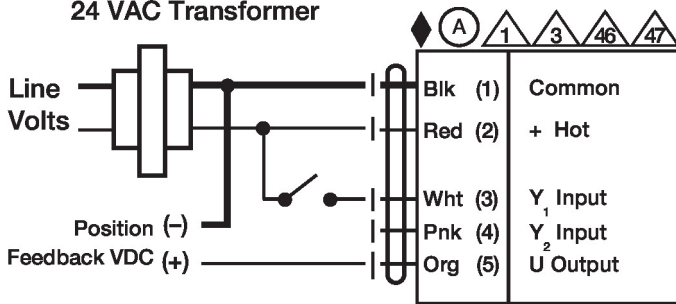

Floating Point

24 VAC Transformer (AC Only)

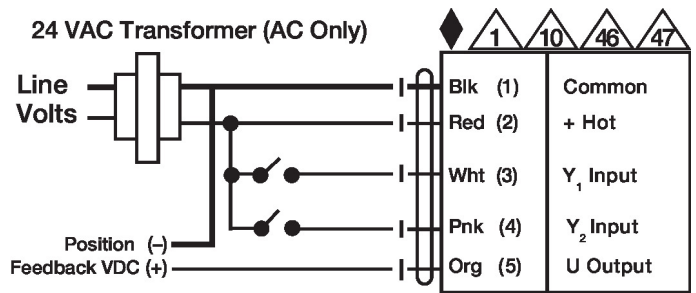

VDC/mA Control

24 VAC Transformer

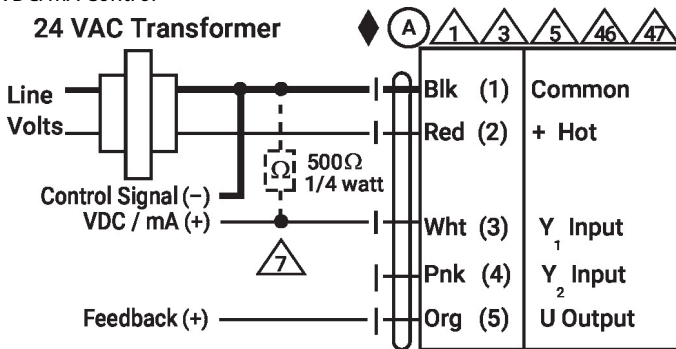

PWM Control

24 VAC Transformer (AC only)

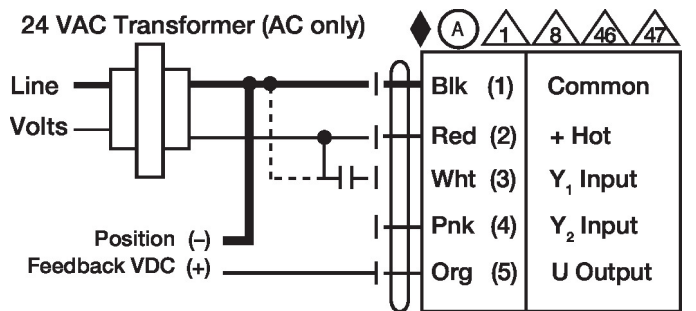

Override Control

24 VAC Transformer (AC Only)

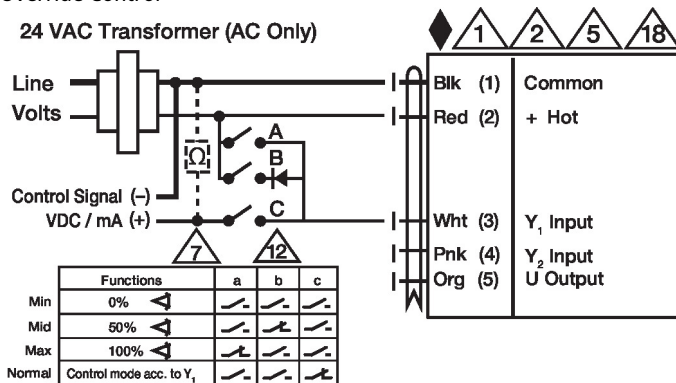

Primary - Secondary

