

Ball Valve (VSS), 2", 2-way, Cv 108

- NSF/ANSI 61 – Water Quality – C. Hot
- NSF/ANSI 372 - Lead Free



2-year warranty

Type overview

Type	DN
B249VSS	50

Technical data

Functional data	Valve size [mm]	2" [50]
	Fluid	chilled or hot water, up to 60% glycol, steam
	Fluid Temp Range (water)	-22...298°F [-30...148°C]
	Body Pressure Rating	1500 psig WOG
	Close-off pressure Δps	1000 psi
	Flow characteristic	modified equal percentage
	Leakage rate	ANSI Class VI
	Pipe connection	Internal thread NPT (female)
	Max Differential Pressure (Steam)	50 psi
	Flow Pattern	2-way
	Controllable flow range	90° rotation, A – AB open ccw, B – AB open cw
	Cv	108
	Maximum Inlet Pressure (Steam)	50 psi
	Maximum Velocity	15 FPS
	Materials	Valve body
Housing seal		PTFE
Stem		316 stainless steel
Stem seal		RPTFE
Seat		RPTFE
Lock nut		stainless steel
Ball		316 stainless steel
Suitable actuators	Non Fail-Safe	GMB(X) PRB(X)
	Spring	AF
	Electrical fail-safe	GKB(X) PKRB(X)

Note: NSF/ANSI/CAN 61 Section 8, Annex G, NSF/ANSI 372 - Drinking Water System Components - Lead Content. Suitable for Cold, Domestic Hot, and Commercial Hot applications.

Product features

Application These threaded valves are designed to provide modulating or two position control of hot or chilled water and saturated steam systems under 50 psi.

Typical applications include reheat coils, VAV terminal control, unit ventilators, and air handlers, especially in areas which have minimum profile requirements.

Up to 50 psi steam

1/2" - 2000 PSIG WOG, Cold Non-Shock

Federal Specification: WW-V-35C, Type II

Composition: SS

Style: 3

Flow/Mounting details

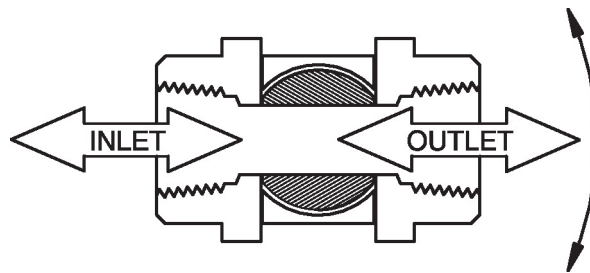

Dimensions

Type	DN	Weight
B249VSS	50	6.2 lb [2.8 kg]

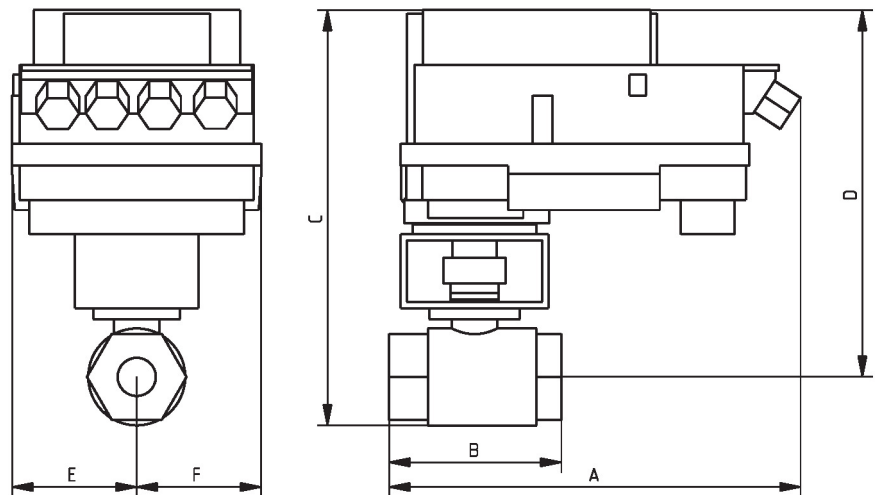

B249VSS+PKR..

A	B	C	D	E	F
12.8" [325]	5.5" [140]	13.3" [337]	11.7" [298]	4.0" [102]	4.0" [102]

On/Off, Floating point, Non fail-safe, 24 V

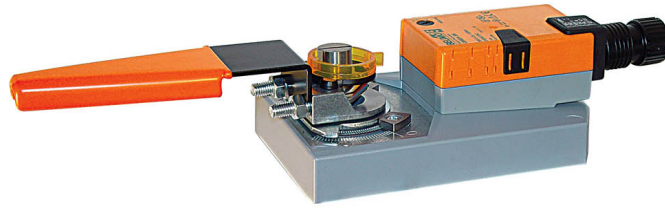

5-year warranty

Technical data

Electrical data	Nominal voltage	AC/DC 24 V
	Nominal voltage frequency	50/60 Hz
	Nominal voltage range	AC 19.2...28.8 V / DC 21.6...28.8 V
	Power consumption in operation	4 W
	Power consumption in rest position	2 W
	Transformer sizing	6 VA
	Electrical Connection	18 GA plenum cable, 1 m, with 1/2" NPT conduit connector, degree of protection NEMA 2 / IP54
	Overload Protection	electronic throughout 0...95° rotation
Functional data	Torque motor	40 Nm
	Direction of motion motor	selectable with switch 0/1
	Manual override	external push button
	Angle of rotation	Max. 95°
	Angle of rotation note	adjustable with mechanical stop
	Running Time (Motor)	150 s / 90°
	Running time motor note	constant, independent of load
	Position indication	Mechanical, 30...65 mm stroke
Safety data	Power source UL	Class 2 Supply
	Degree of protection IEC/EN	IP54
	Degree of protection NEMA/UL	NEMA 2
	Enclosure	UL Enclosure Type 2
	Agency Listing	cULus acc. to UL60730-1A/-2-14, CAN/CSA E60730-1:02 CE acc. to 2014/30/EU and 2014/35/EU
	Quality Standard	ISO 9001
	UL 2043 Compliant	Suitable for use in air plenums per Section 300.22(C) of the NEC and Section 602 of the IMC
	Ambient humidity	Max. 95% RH, non-condensing
	Ambient temperature	-22...122°F [-30...50°C]
	Storage temperature	-40...176°F [-40...80°C]
	Servicing	maintenance-free
Weight	Weight	4.1 lb [1.9 kg]
Materials	Housing material	Galvanized steel and plastic housing

Technical data

Footnotes †Rated Impulse Voltage 800V, Type action 1, Control Pollution Degree 3.

Accessories

Electrical accessories	Description	Type
	Battery backup system, for non-spring return models	NSV24 US
	Battery, 12 V, 1.2 Ah (two required)	NSV-BAT
	Feedback potentiometer 140 Ω add-on, grey	P140A GR
	Feedback potentiometer 500 Ω add-on, grey	P500A GR
	Feedback potentiometer 1 kΩ add-on, grey	P1000A GR
	Feedback potentiometer 2.8 kΩ add-on, grey	P2800A GR
	Feedback potentiometer 5 kΩ add-on, grey	P5000A GR
	Feedback potentiometer 10 kΩ add-on, grey	P10000A GR
	Auxiliary switch 1x SPDT add-on	S1A
	Auxiliary switch 2x SPDT add-on	S2A

Electrical installation

✂ INSTALLATION NOTES

- (A)** Actuators with appliance cables are numbered.
- (1)** Provide overload protection and disconnect as required.
- (3)** Actuators may also be powered by DC 24 V.
- (6)** Actuators Hot wire must be connected to the control board common. Only connect common to neg. (-) leg of control circuits. Terminal models (-T) have no-feedback.
- (11)** Actuators may be connected in parallel if not mechanically linked. Power consumption and input impedance must be observed.
- (♦)** Meets cULus requirements without the need of an electrical ground connection.
- (1)** **Warning! Live electrical components!**
 During installation, testing, servicing and troubleshooting of this product, it may be necessary to work with live electrical components. Have a qualified licensed electrician or other individual who has been properly trained in handling live electrical components perform these tasks. Failure to follow all electrical safety precautions when exposed to live electrical components could result in death or serious injury.

Wiring diagrams

On/Off

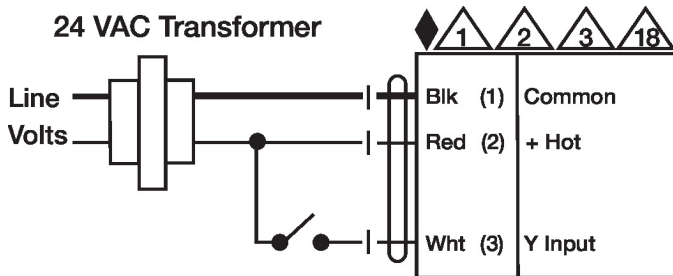

Floating Point

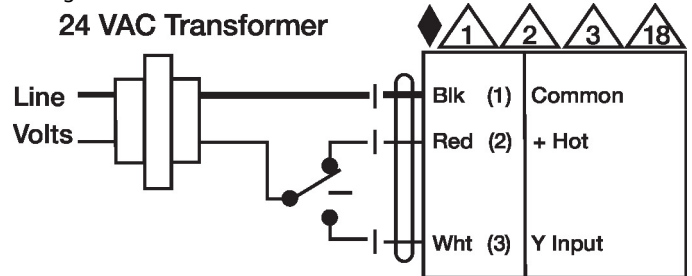

Electrical installation

Wiring diagrams

24 VAC Transformer

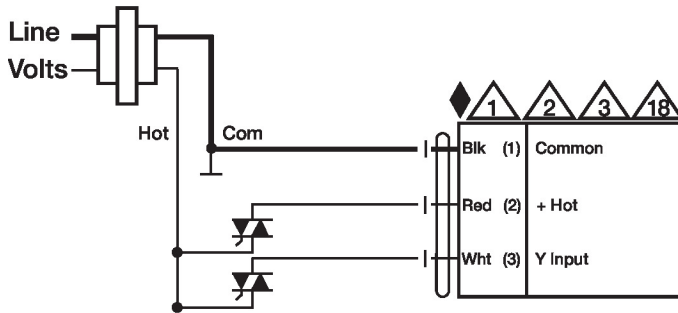

Floating Point - Triac Sink
24 VAC Transformer

