

Potable water valve, 2-way, Press fit

- For potable water applications
- NSF/ANSI 372 - Lead Free
- NSF/ANSI 61 – CLD 23 – Water Quality



5-year warranty



Technical data

Functional data	Valve size [mm]	0.5" [15]
	Potable water certificate	NSF/ANSI 61 NSF/ANSI 372
	Fluid	Potable water
	Fluid temperature	-4...212°F [-20...100°C]
	Body Pressure Rating	250 psi CWP
	Close-off pressure Δps	200 psi
	Differential pressure Δpmax	30psi
	Leakage rate	0%
	Angle of rotation	90°
	Pipe connection	Press fit
	Installation orientation	upright to horizontal (in relation to the stem)
	Servicing	maintenance-free
	Flow Pattern	2-way
	Cv	32
Materials	Valve body	Lead free brass
	Stem	Lead free brass
	Seat	PTFE
	O-ring	EPDM
	Ball	Chrome plated lead free brass
Suitable actuators	Non Fail-Safe	CQB(X)
	Electrical fail-safe	CQKB(X)

Safety notes



- The ball valve has to be exercised at least once a week, so that the quality of potable water as well as the functionality are not affected.
- The valve has been designed for use in stationary potable water systems and must not be used outside the specified field of application, especially in aircraft or in any other airborne means of transport.
- The valve does not contain any parts that can be replaced or repaired by the user.

Product features

- Operating mode** The on/off ball valve is adjusted by a rotary actuator. The rotary actuator is connected by an on/off signal. Open the ball valve counterclockwise and close it clockwise.

Installation notes

Notes The ball valve is a regulating device. To fulfil this control task in the long term, the circuit must be kept free from particle debris (e.g. welding beads during installation work).

Permissible installation orientation The ball valve can be installed upright to horizontal. The ball valve may not be installed in a hanging position, i.e. with the stem pointing downwards.

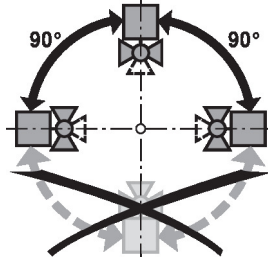

Servicing Ball valves and rotary actuators are maintenance-free. Before any service work on the control element is carried out, it is essential to isolate the rotary actuator from the power supply (by unplugging the electrical cable if necessary). Any pumps in the part of the piping system concerned must also be switched off and the appropriate slide valves closed (allow all components to cool down first if necessary and always reduce the system pressure to ambient pressure level).

The system must not be returned to service until the ball valve and the rotary actuator have been correctly reassembled in accordance with the instructions and the pipeline has been refilled by professionally trained personnel.

Flow direction Please also ensure that the ball is in the correct position (marking on the shaft).

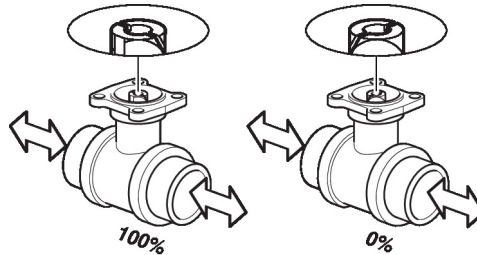

Dimensions

DN
15

Weight
0.53 lb [0.24 kg]

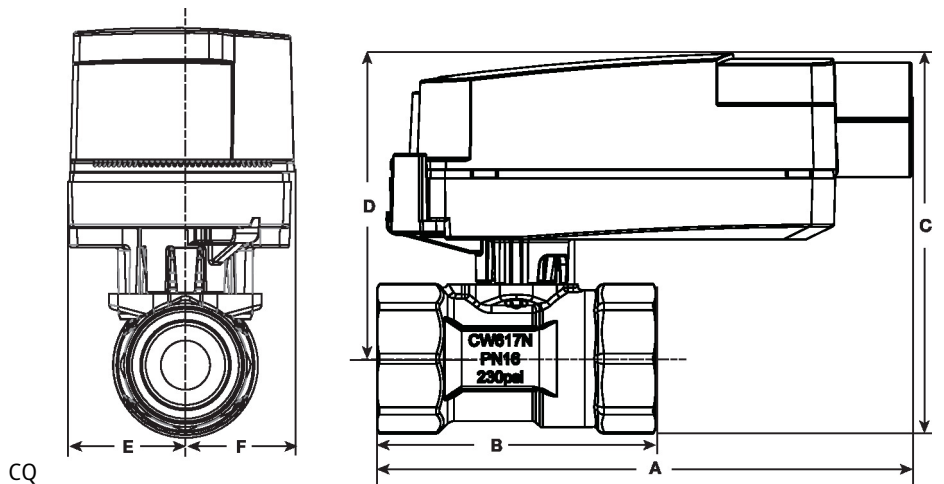

Dimensions

A	B	C	D	E	F
5.0" [127]	3.1" [78]	3.3" [83]	2.7" [69]	0.9" [24]	0.9" [24]

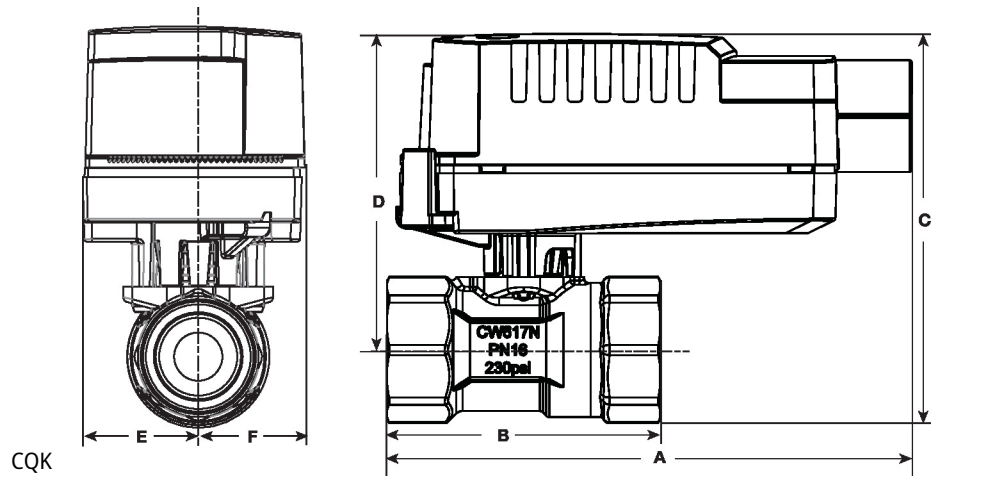

A	B	C	D	E	F
5.0" [127]	3.1" [78]	3.4" [87]	2.8" [70]	0.9" [24]	0.9" [24]

On/Off, Electrical fail-safe, 24 V

- Nominal voltage AC/DC 24 V
- Control On/Off

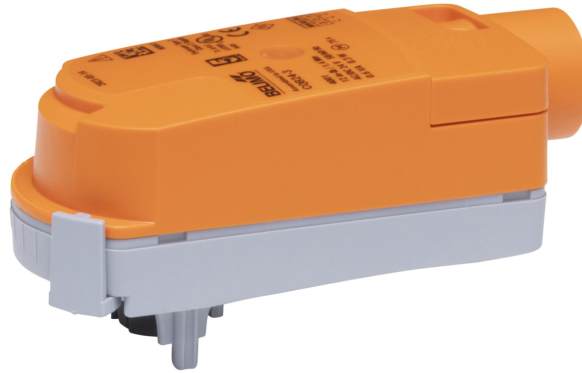

5-year warranty



Technical data

Electrical data	Nominal voltage	AC/DC 24 V
	Nominal voltage frequency	50/60 Hz
	Nominal voltage range	AC 19.2...28.8 V / DC 21.6...28.8 V
	Power consumption in operation	2.5 W
	Power consumption in rest position	0.5 W
	Transformer sizing	5 VA
	Auxiliary switch	1x SPST, 1 A resistive @ DC 30 V
	Switching capacity auxiliary switch	1 A resistive @ DC 30 V
	Electrical Connection	22 GA plenum cable, 3 ft [1 m], with 1/2" NPT conduit connector
	Overload Protection	electronic throughout 0...90° rotation
Electrical Protection	actuators are double insulated	
Functional data	Bridging time (PF)	2 s
	Pre-charging time	5...20 s
	Angle of rotation	90°
	Angle of rotation note	adjustable with mechanical stop
	Running Time (Motor)	75 s / 90°
	Running time fail-safe	<60 s
	Noise level, motor	35 dB(A)
	Noise level, fail-safe	35 dB(A)
Position indication	pointer	
Safety data	Power source UL	Class 2 Supply
	Degree of protection IEC/EN	IP40
	Degree of protection NEMA/UL	NEMA 2
	Enclosure	UL Enclosure Type 2
	Agency Listing	cULus acc. to UL60730-1A/-2-14, CAN/CSA E60730-1:02 CE acc. to 2014/30/EU and 2014/35/EU
	Quality Standard	ISO 9001
	UL 2043 Compliant	Suitable for use in air plenums per Section 300.22(C) of the NEC and Section 602 of the IMC
	Ambient humidity	Max. 95% RH, non-condensing
	Ambient temperature	35...104°F [2...40°C]
	Storage temperature	-40...176°F [-40...80°C]
Servicing	maintenance-free	

Technical data

Weight	Weight	0.57 lb [0.26 kg]
Materials	Housing material	UL94-5VA

Product features

Application Electrical fail-safe On/Off ZoneTight actuator.
 Valve selection should be done in accordance with the flow parameters and system specifications. The actuator is mounted directly to the valve without the need for tools or additional linkage.
 The actuator operates in response to AC/DC 24 V.
 Angle of rotation is adjustable with the integrated mechanical stop.

Electrical installation

✂ INSTALLATION NOTES

- (A)** Actuators with appliance cables are numbered.
- 1** Provide overload protection and disconnect as required.
- 2** Actuators may be connected in parallel. Power consumption and input impedance must be observed.
- 3** Actuators may also be powered by DC 24 V.
- 18** Actuators with plenum cable do not have numbers; use color codes instead.
- 100** One built-in auxiliary switch, 1x SPST 1 A @ DC 30 V (resistive load), for end position indication, interlock control, fan startup, etc.
- ◆** Meets cULus requirements without the need of an electrical ground connection.
- ⚡** Apply only AC line voltage or only UL-Class 2 voltage to the terminals of auxiliary switches. Mixed or combined operation of line voltage/safety extra low voltage is not allowed.
- ⚠ Warning! Live electrical components!**
 During installation, testing, servicing and troubleshooting of this product, it may be necessary to work with live electrical components. Have a qualified licensed electrician or other individual who has been properly trained in handling live electrical components perform these tasks. Failure to follow all electrical safety precautions when exposed to live electrical components could result in death or serious injury.

Wiring diagrams

AC 24 V Transformer

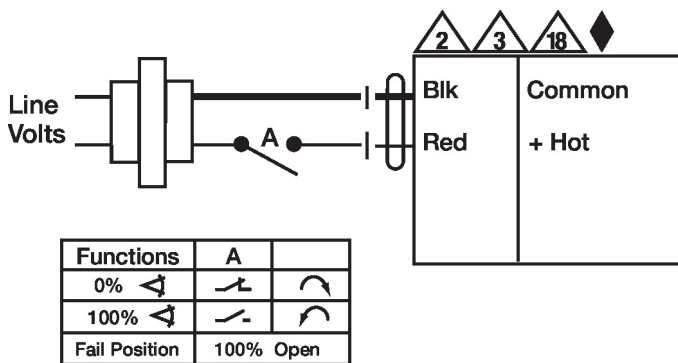

Auxiliary Switch

