

# Basic Training - Fire & Smoke Damper Actuator Replacement

**TYPICAL MECHANICAL DETAILS**

For added strength, use an 18-20 ga. steel base plate, secured with sheet metal screws.

Jackshaft larger than 3/4 inch O.D.

AF... NF... Type actuators

Top of actuator

Fig. 1.12 ZG-AF Damper linkage kit Kit contains:

- 1 crankarm with retaining clip,
- 2 standoff brackets,
- 4 mounting feet,
- 2 bolts w/ nuts,
- 2 ball joints

## Introduction

This document's intent is to provide a Basic Introduction to Fire & Smoke damper actuator replacement. The document includes commonly seen damper installation methods, challenges and solutions to a variety of typical replacement applications.



***WARNING!***

**Installer must be trained and experienced with repair of fire and smoke dampers and actuators.**

For specific details on any application, please contact:  
Mike Bracero at 203-749-3105 (East Coast)      Larry Felker at 775-857-4243 x 5205 (West Coast).

For more extensive information go to:

[www.belimo.us/firesmoke](http://www.belimo.us/firesmoke)

### Table of Contents

- Introduction.....2
- Standards and Codes .....4
- Replacement Issues.....5
- Combination Fire and Smoke Damper Types and Examples.....6
  - External Single Spring with Fusible Link .....7
  - Dual Springs with Fusible Link .....7
  - McCabe Link® .....9
  - Other Prefco Dampers .....9
  - Negator Spring – Ruskin and Air Balance-American Warming.....10
  - External Spring.....11
  - Typical Installation of Internal Spring Actuators.....12
- Mounting Methods and Typical Accessories.....13
- Fire Marshal Notification Form.....19

### **WARNING - Note on Alarm Systems or Smoke Control Systems**

If any wiring to an alarm or smoke control has been touched, the Fire Marshal may require verification that the system remains functional.

In some cases the auxiliary switches of the actuator are used to signal status to a smoke control system. Function cannot be disturbed.

In some cases the auxiliary switches power local indicator lights. These have only supervisory function and are not part of the fire alarm system.

**Verify requirements with Authority Having Jurisdiction (AHJ)  
– Fire Marshal or Building Official.**



**In all cases, installation must comply with any and all local electrical and life safety codes. Operation of the system after installation must be performed to verify proper damper cycling. Final checkout requires verifying correct function.**

**The important points that should be taken from this document are:**

- 1. The same actuator can be applied several ways since fusible links, thermal sensors, and external springs can be applied different ways to achieve the same result.**
- 2. Investigation of each damper should be performed to identify the right way to repair.**
- 3. After determination of the repairs necessary, performance testing must be performed.**

## Definitions



**Fire Dampers** are rarely actuated in the United States. Most Fire Dampers are gravity dampers or spring loaded and released by a heat activated fusible link.

Photo Courtesy Pottorff



**Smoke Dampers** do not have a high temperature limit. Older actuators without internal springs depended on a shaft or external spring to close the damper whenever the actuator power is removed.



**Combination Fire & Smoke Dampers** combines the smoke sealing capabilities of a standard smoke damper with the high temperature capability of a fire damper. Combination Fire & Smoke dampers are tested in accordance to UL555 and UL555S.

Photo Courtesy Pottorff

## Standards and Codes

### UL

In Underwriters Laboratories Inc®, April 2003 publication “Marking & Application Guide, Dampers for Fire Barrier and Smoke Applications & Ceiling Dampers” page 6, they state:

#### **DAMPER ACTUATORS**

“... field mounting or substitution of actuators is not covered within the scope of the UL certification of the product. However, this does not necessarily preclude replacement of actuators in the field. Like any appliance, field servicing of these products is not covered under the scope of the UL certification and factory follow-up service program. As with any part of the damper, it is expected that replacement of actuators in the field be done in accordance with the damper manufacture’s normal field servicing program.”

## NFPA

Repair recommendations can be found in **NFPA 80** Standard for Fire Doors and Other Opening Protectives, 2007 Edition and **NFPA 105** Standard for the Installation of Smoke Door Assemblies and Other Opening Protectives 2007 Edition

**Fire & smoke dampers are considered to be appliances and field replacement of defective parts is required. NFPA also says “after discovering a failure repair should be performed as soon as possible.”**

## Local Codes

The administrative section of codes state that all mechanical and electrical systems must be kept in working order and an individual code section may state that all life safety devices and systems must be operable. Codes rarely address replacement issues in any detail. Consult the Fire Marshal and/or Building Department for local requirements. A permit and inspection could be required if a large number of actuators are being repaired. Some jurisdictions place a limit on the number of devices to be replaced before a permit is required. If wiring to the fire alarm or smoke control system is touched, then the fire department must be informed. Some actuator auxiliary switches are used to signal the Fire Fighters Smoke Control System or Fire Alarm. If so, and an actuator with aux switches is replaced, the fire department should be informed.

In all cases, a record should be left on the premises when an actuator (or any other part of a damper) is replaced. The form on the last page may be used if no official form is available locally.

## *Replacement Issues*

Change has obsoleted many combinations of products. Some actuators and dampers are no longer manufactured and no current UL555 listings exist. In lieu of other clearly defined replacement criteria, the following technical rules are recommended practice:

1. It is standard procedure for damper manufacturers to obtain UL555S listing with several actuators for the same damper. Where the actuator being installed is UL555S listed, no further requirements are necessary provided the temperature, time, torque, voltage, amperage are matched correctly and conformance testing is performed. That is, the correct model must be installed and the assembly tested.
2. Damper manufacturers have installation instructions for replacement of actuators on some dampers. These should be obtained and utilized. In the past UL allowed field installation of actuators and it was sufficient to use the instructions. UL no longer oversees field or replacement applications.
3. Where older dampers or actuators are involved and are no longer manufactured the following rules should apply:

- a. Check damper itself for proper operation. Clean all components insure that shifting of ducts or damage to side seals has not restricted closure, or failure of mechanical parts has not occurred over time. Do not replace the actuator or any components if the entire assembly is not functional. The warning below appears in the instruction sheets.



**Before replacing actuator, damper must be inspected and determined to be fully functional.**

- b. **Temperature** – the replacement actuator shall operate at the rating of the original actuator – 250°F or 350°F.
- c. **Torque** – replacement actuator shall have equal or greater torque than the failed actuator.
- d. **Time** – the replacement actuator shall drive open and spring closed at the speed required by codes or as directed by Fire Marshal. In general, use same or faster time as original.
- e. **Voltage** – replacement actuator shall have the same voltage rating as the original.
- f. **Amperage** – the replacement actuator(s) shall not draw more amperage than the original(s) and cause the total amperage to rise above that which the electrical circuit breaker is designed to carry.
- g. **Testing** – actuated damper and associated devices shall be tested for proper operation.  
See Fire Marshal form on last page.
- h. Where any **structural modification** is made, a permit is required.
- i. Where change from **pneumatic to electric** is performed, a permit is required. In addition, the damper manufacturer's instructions, wiring diagrams, and other components (e.g., elevated 250°F thermal disks for electrical interruption) must be used.
- j. AHJ should be consulted to obtain local rules which do vary among jurisdictions.

***Note that smoke dampers do not have high temperature limits, bimetals, or fusible links. Therefore, regardless of spring type, a Belimo with internal spring can be employed after disabling the old spring. The following applies to combination fire and smoke dampers.***

## ***Combination Fire and Smoke Damper Types and Examples***

## External Single Spring with Fusible Link

- **It may be necessary to disable the old spring and primary sensor, install modern actuator, and install a modern thermal sensor.**

Some dampers had a single spring that was tensioned when the actuator was driven open; the actuator held the damper open when powered. Pottorff and Accurate used this method on some dampers.

Then if the smoke detector or relay cut power to the actuator, the shaft spring drove the damper closed.

If the fusible link melted due to elevated temperature (165°F typically), then the connection between the damper and the actuator was separated. The spring then engaged and closed the damper. The actuator could not drive the damper back open until the fusible link was manually replaced and the connection remade.

There were several variations of this. One was a flat “negator” spring that touched the damper blade itself. Another was a spring wrapped around the jackshaft. Another had a spring built into the crank arm. American Warming / Air Balance and Ruskin had several versions like this. Pottorff used this method also. See next section.

Dampers that used any of these methods require that the spring be removed or disconnected and the fusible link be removed or bypassed if a new actuator is to be installed. An electrical thermal sensor (thermodisc) must also be installed. An exception exists with Ruskin dampers less than 1 sq.ft.

The damper manufacturer’s instructions must be used for the repair since changes to the damper are being made. AHJ should be consulted regarding the need for witnessing the testing.

A Belimo actuator may be installed after making the proper damper modifications.

## Dual Springs with Fusible Link

- **In most cases, simply installing a new actuator repairs the damper function.**

Most companies used two springs. One was pre-tensioned and the fusible link held it ready. If the link melted, the damper slammed closed. This spring was not a load on the actuator. An external spring (example shown to right) was used to close the damper when the actuator was not powered. When the actuator drove open, it tensioned this spring.

This is similar to a modern damper actuator operation. When replacing the actuator, the second actuator spring must be removed – NOT THE FUSIBLE LINK SPRING. The new actuator would have to operate against its own internal spring and the

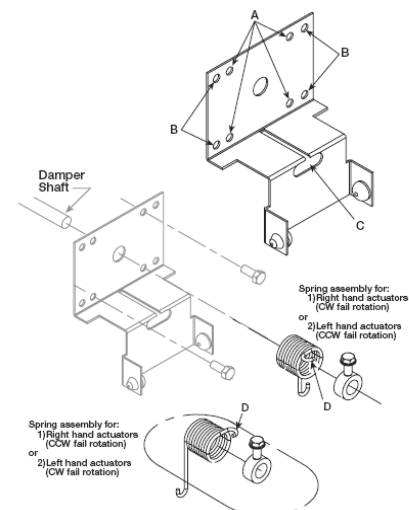

external spring – a larger actuator would be required and that application is not UL Listed. A Belimo FS actuator may be installed after removing the defective actuator and external spring. Any assembly should be examined to see if a fusible link exists and how the fusible link is set up. This could be a smoke damper and no high limit exists. Different damper companies mounted and applied the same actuator in different ways.

**The warning below is placed in instruction sheets. In addition, do not place hands between damper blades. Inadvertent release of actuator or springs can allow injury to occur.**



***USE CAUTION!***

**Spring is under high torsion and may cause serious injury! If any external springs are present, exercise caution – wear face and hand protection.**



## McCabe Link®

See drawing at right.

Prefco manufacturing used a special bimetal assembly for the elevated temperature limit. Many dampers can accept a modern Belimo actuator and work perfectly.

The spring is tensioned when the actuator drives open the first time. For this reason, extra actuator torque is needed. Once pretensioned, the spring is no longer a load on the actuator. Instead of using 4 sq.ft. per FSLF, 18" X 18" is the maximum damper size. The FSNF may be used for dampers up to 12 sq.ft.

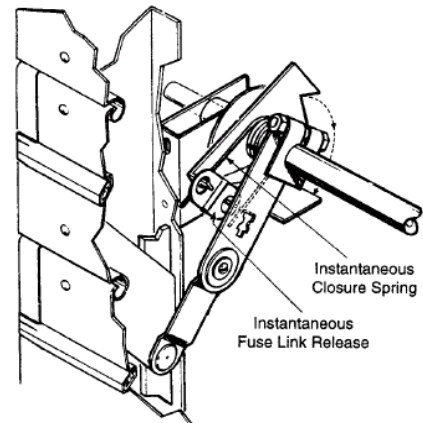

## Other Prefco Dampers

Some models used a special pulley-cable and mount for the motor. There is no damper shaft available for either direct or linkage mounting. See 5800 EMB drawings. The Belimo FS Series actuators cannot be used with these. Call Belimo for information or see Belimo Dashboard for cross reference data. Each case needs to be examined to determine the correct method for installation. Some parts are available and the damper manufacturer needs to be contacted for information on modification to a UL approved version. In many cases, the whole damper must be replaced.

**5800 EMB 2X-PC**  
(Power Closed -  
Spring Open  
(TYPICAL))

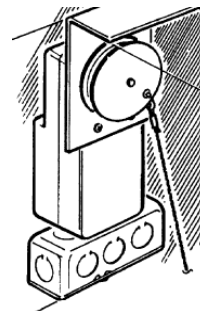
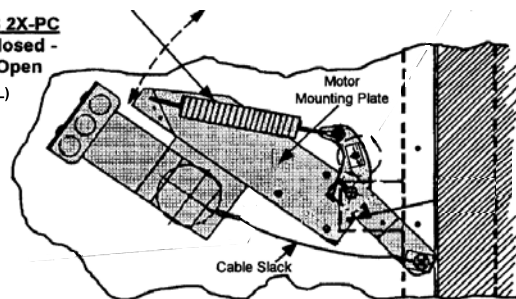

### 5800 EMB

Belimo cannot be used to replace the above motors unless a 1/2" shaft is present.

**Modern Prefco dampers use thermal sensors and spring return motors. Replacement is straightforward.**

## Negator Spring – Ruskin and Air Balance-American Warming

**SOME NEGATOR SPRING DAMPERS USED THERMAL SENSORS, SOME USED FUSIBLE LINKS OR RODS. CHECK APPLICATION BEFORE REPLACING ACTUATOR**



The **black arrow** points to the spring. The **red arrow** points to the fusible link.

Instructions from Air Balance are available for modification of the damper to modern methods. A thermodisc, new linkages, external shaft to actuator bracket, and new actuator are required as well as formal testing.

If access permits, a new damper may be the best technical solution.



Instead of a fusible link, a fusible rod is used here.

**Black arrows** point to springs and the **red arrow** to the fusible rod.

*These applications require special factory contact for repair and retrofit of actuators. Some kits exist already and some may need to be put together.*

Obtain make and model of damper and actuator for replacement information.  
**Careful use of instructions required as well as AHJ approval.**

Better than leaving the old negator spring and making the actuator do extra work holding it open is to install a Belimo BAE165 and an actuator while bypassing the old mechanical parts. Approval from the AHJ must be obtained before making these changes. Replacing the damper itself is recommended when extensive changes are necessary to bring it up to modern control methods.

Call for instructions to submit to AHJ.

## External Spring

- **In the vast majority of cases, removing the old spring and motor and installing a new actuator repairs the damper function.**

**SINGLE SPRING WITH THERMODISC.** (Method used by Ruskin for many years.) There was an external spring that was tensioned when the actuator drove open. There was no fusible link or shaft spring. This functioned like a modern internal spring actuator. See photograph below.



**The old motor and spring are disassembled and removed.**

Then a Belimo can be direct coupled in the old motor's place.

A thermodisc was used initially and cut power if the temperature rose. Both linkages and direct coupled methods were used and both have passed UL555(S).

The external spring and non-spring actuator function identically to a modern actuator with an internal spring.



These functioned like a modern internal spring actuator. Check the fusible link operation in case some modifications have been made and function needs to be reestablished.



The linkage and actuator are removed and the Belimo FS actuator mounts on the shaft.

## Typical Installation of Internal Spring Actuators

### ***Modern (fire & smoke) damper actuators have internal springs.***

1. **SHAFT SPRING WITH FUSIBLE LINK.** Some dampers have the fusible link and shaft spring and a spring return actuator. The damper functions as the dual spring method detailed above.

The actuator can be replaced without modifying the damper, shaft, spring, or link. This is because the shaft spring only functions with the fusible link and is not required to close the damper if power is removed from the actuator. The actuator's internal spring accomplishes that function in response to the smoke detector or smoke relay controlled from the area smoke detectors.

2. **STANDARD ACTUATOR AND THERMODISC(S) – ACTUATOR SPRING ONLY.** The smoke detector or smoke relay or thermodisc cuts power to the actuator and it springs the damper closed. Other than basic technical specifications – torque, voltage, current draw, speed, and mounting - actuators are interchangeable.

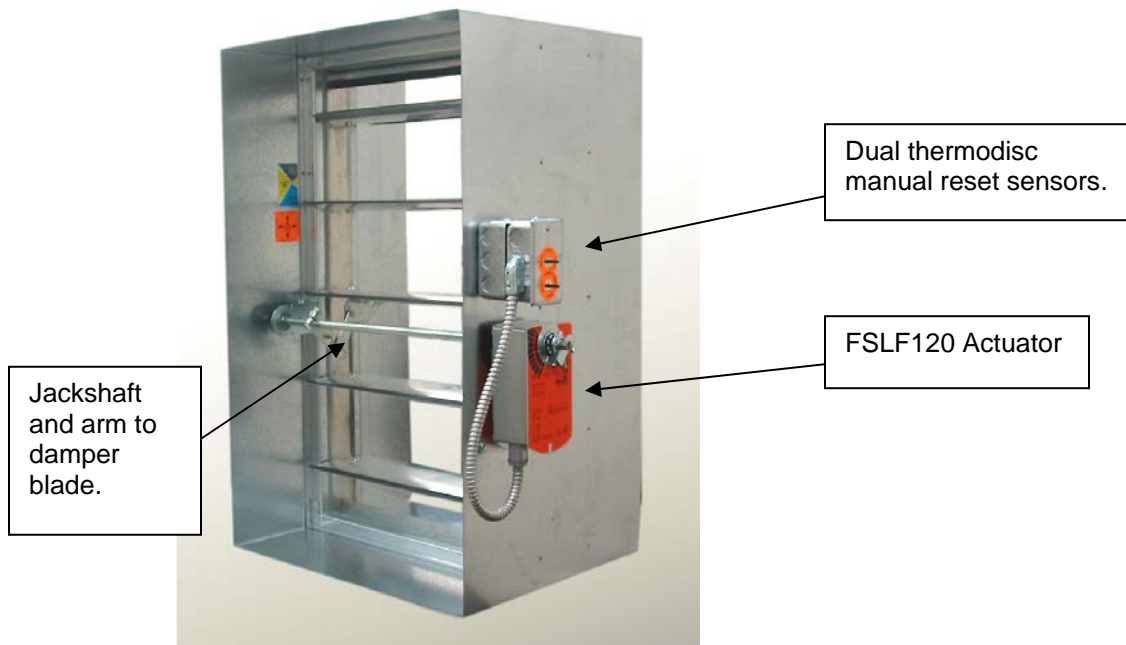

Photograph courtesy Pottorff Division of PCI

### ***Summary***

Smoke dampers had no high temperature limit and are simpler to repair in general.

There are three general methods for controlling combination fire and smoke dampers:

1. Single spring with motors without springs. Damper must be rebuilt with manufacturer assistance and/or instructions. Contact Belimo for more information.
2. Two springs – one for the fusible link, one for the actuator. Remove defective motor and spring; mount Belimo.
3. Modern method with spring inside actuator. Remove defective and replace.

## Mounting Methods and Typical Accessories

Mounting of replacement actuators is dependent upon individual applications, site requirements, and type of equipment being replaced. A selection of accessories and mounting kits are available. See [http://www.belimo.us/bellib/Accessories/Mechanical\\_Access](http://www.belimo.us/bellib/Accessories/Mechanical_Access).

Typical example illustrated below:

When needed, use a chase nipple to connect electrical J-box to the Belimo ½" conduit connector. A 4" x 4" box can be used when the auxiliary switch wiring goes into a conduit.

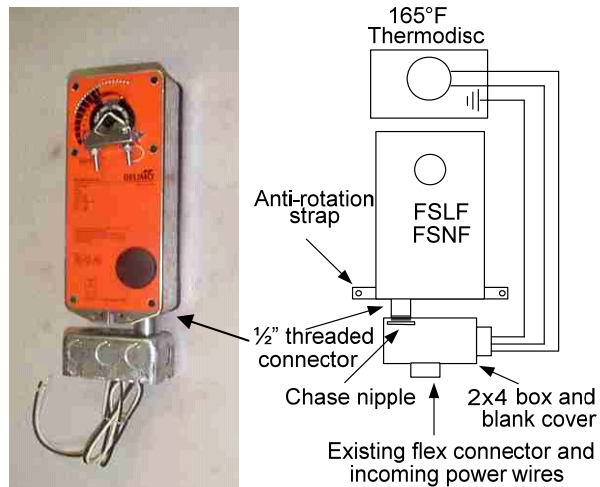

Check damper manually for smooth operation before mounting actuator. Good installation includes mounting the actuator straight and level. Bend the anti-rotation strap at the slots to clear the actuator's splines and any obstructions. Mount in correct spring return direction. Drive open and closed three times to ensure proper operation.

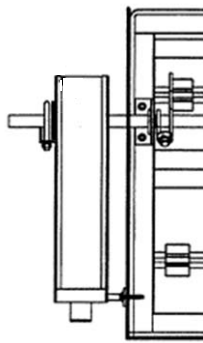
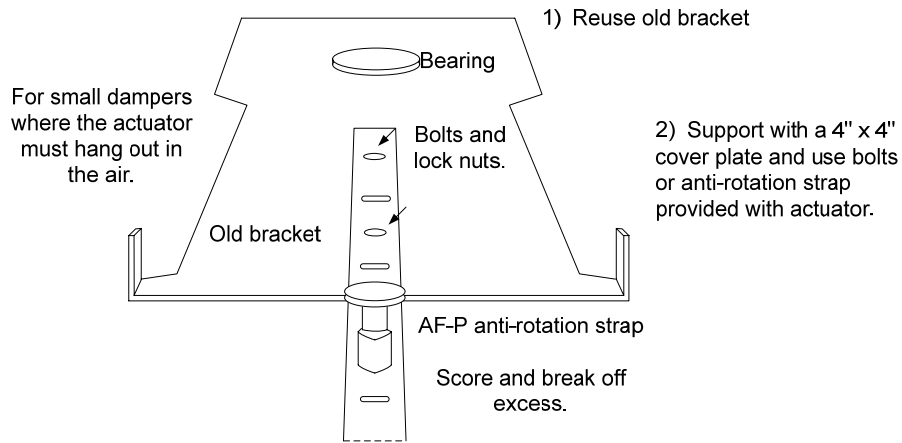
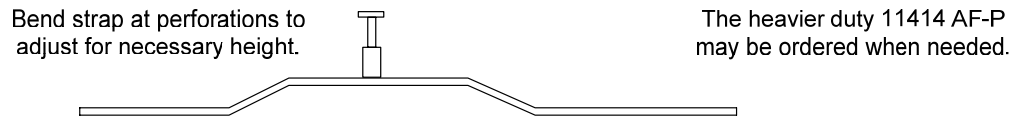
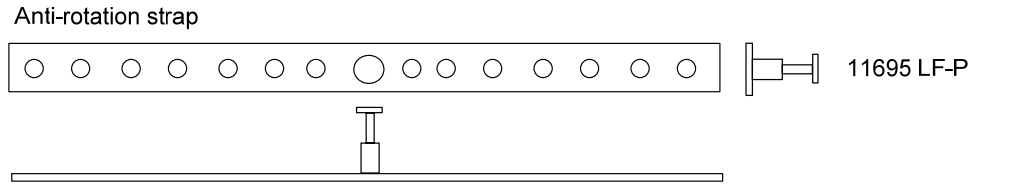

On occasion, a stable platform may be required to securely mount the new actuator. For a complete review of available mounting hardware, download the Mechanical Accessories guide from the Belimo website.

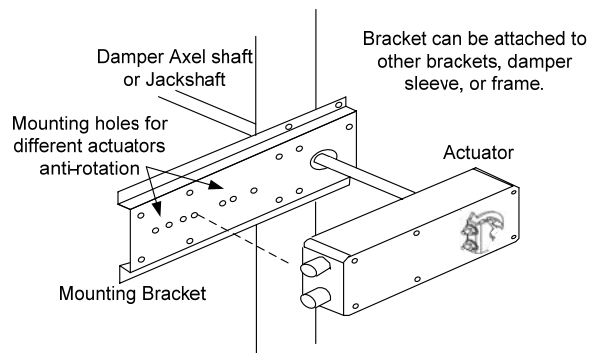

Platform brackets are available from some damper OEM's.

*Shaft adaptors available in Mechanical Accessories guide.*

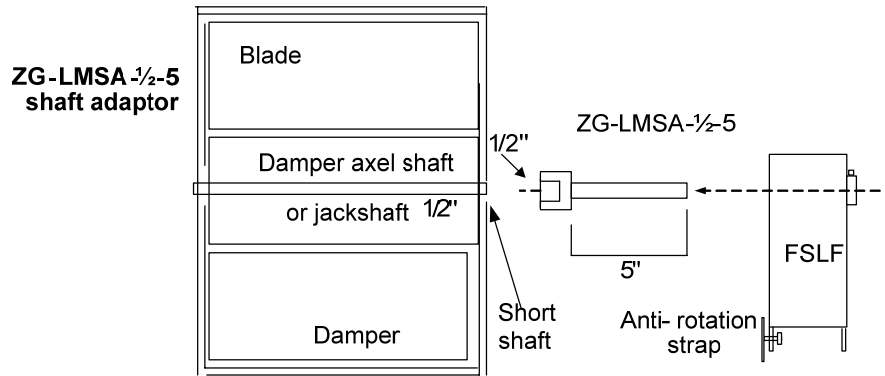

The following warnings are in installation sheets. The first is a life safety and code issue. The second an advisory. The third protective to the service technician.



***WARNING!***

**Actuator anti-rotation strap may not be screwed to the duct. It must attach to either the sleeve or to the mounting bracket. The duct must be able to fall away from the damper in case of ceiling collapse in a fire.**



***WARNING!***

**Read Data Sheet provided in box with each actuator for specific wiring details.**



***WARNING!***

**Disconnect and lock out power before starting to disconnect old motor.**

## Ruskin Damper with MultiProducts Motor to Belimo FSLF120

In order to adapt the old MP motor with its .2" square male shaft end, a female socket was welded onto the damper shaft. The welded piece must stay on the shaft. A shaft adapter insert and actuator with hold down bracket is available from Ruskin.

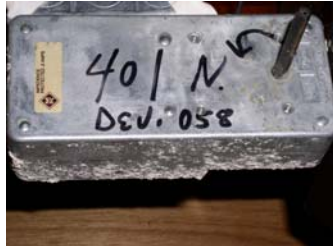

MP2781 was used on FSD60, FSD36, FSD35, FSD34, SD60, SD36, SD35 and SD34. FSD is Fire & Smoke Damper. SD is Smoke Damper.

RETROFIT KIT FOR CONVERTING A DEFECTIVE MP2781 TO FSLF SERIES ACTUATOR.

Ruskin part number **FSLF120/MP**. This must be ordered from local rep or Ruskin Manufacturing. **816-761-7476**

Kit contains actuator, shaft adaptor, hold-down, and instruction sheet.

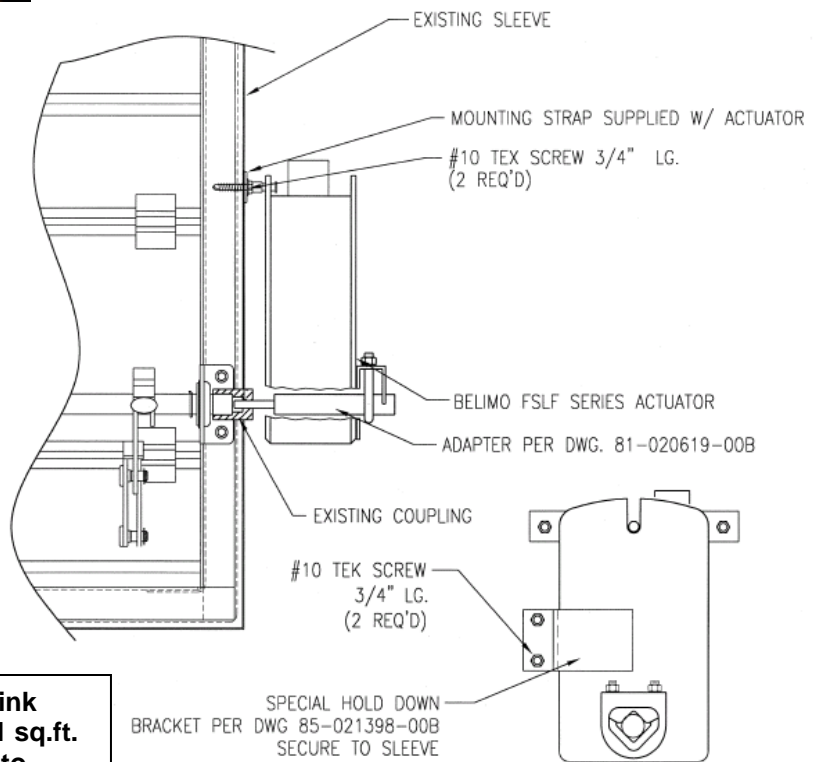

**This was a negator spring and fusible link application. As long as the damper is 1 sq.ft. or less, Ruskin allows a FSLF actuator to replace the old MultiProducts. If the negator spring is broken, replace the damper.**

ACTUATOR HOLD DOWN  
CUSTOMER MUST VERIFY JACKSHAFT ROTATION

**WARNING!**

There was a model similar to the one above that had a shaft spring and fusible rod or link. One was made by Ruskin and one by Air Balance.

The link disconnected the actuator and the spring drove the damper closed. The actuator has to work against the external spring as well as its own internal spring.

**The FSNF should be used for that application to ensure sufficient torque.**

Contact Belimo or damper manufacturer with model number of damper and actuator to obtain replacement instructions.



## Typical Wiring Methods

Where there is a separate damper spring like the Ruskin example above, wiring will be like this:

### DUAL SPRING DAMPER ACTUATOR WIRING

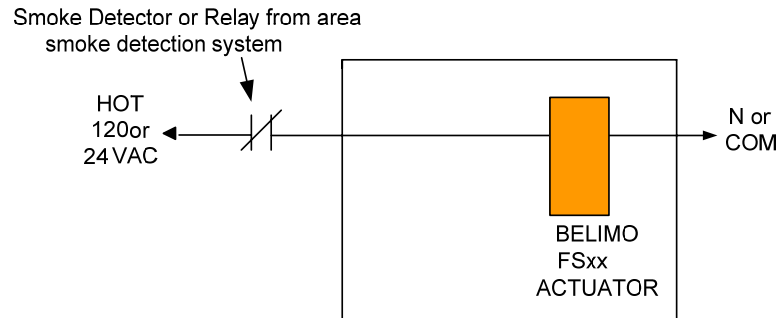

Approximately 85% of modern dampers are wired with a single thermodisc:

### Electric thermal disc

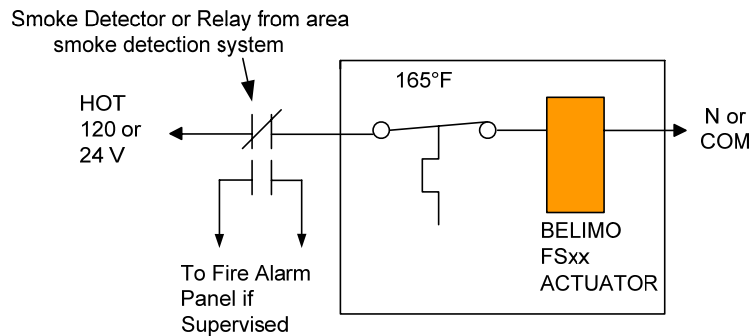

Fusible link dampers do not have the 165°F thermodisc.

About 15% of dampers are installed with a Fire Fighters Smoke Control System override:

### TYPICAL REOPENABLE DAMPER with FSCS

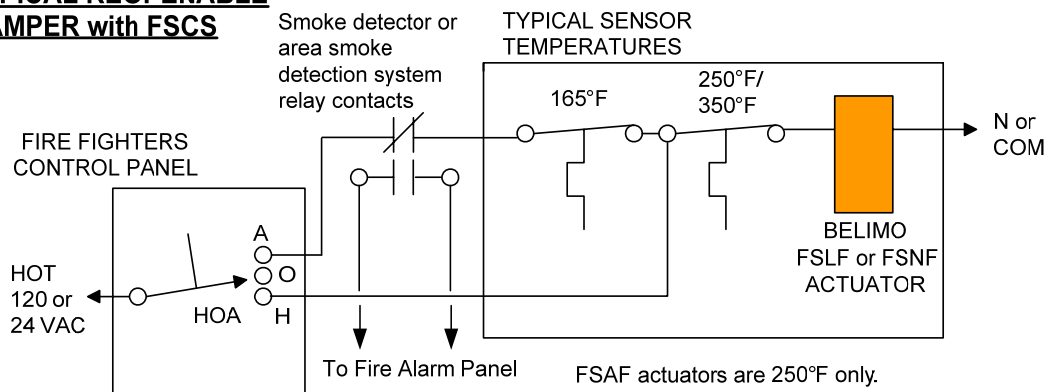

***In all cases, investigate and determine correct wiring methods. These are typical.***

*Example*

Two old motors can be seen. The procedure for replacement was:

1. Disconnect and tag all wiring.
2. Remove old linkage, external spring, & motors.
3. Check and clean dampers. Exercise open and close manually.
4. Damper shafts were available so existing brackets were relocated and used to mount FSNF120 actuators and anti-rotation straps. (FSLF was sufficient for torque; however linkage convenience of FSNF was desired.)
5. Thermal sensors were present and tested.
6. Wiring was cleaned up and connected.
7. Testing to assure operation per check list was performed.

**WARNING!**

**THIS IS A TRAINING DOCUMENT. IT DOES NOT CONTAIN INSTRUCTIONS REQUIRED FOR REPAIR & REPLACEMENT OF DAMPERS & ACTUATORS.**

**Consult Belimo or damper manufacturer for specific make and model instructions.**



## Fire Marshal Notification Form

See NFPA 80 & 105 and UL for maintenance and repair requirements.

Retain this portion of check list at premises for Fire Marshal inspection. Consult AHJ for other information and requirements.

Test Checklist (Smoke dampers do not have sensors. Only steps a & b apply.)

### 1. Single Sensor Combination Damper

- a.  Open smoke detector or relay wire or contact to cut power. *Damper springs closed.*
- b.  Reconnect power. *Damper drives open.*
- c.  Open thermal sensor using heat gun. *Damper springs closed.*
- d.  Press thermal sensor manual reset. *Damper drives open.*

Repeat 3 times to ensure operation. This imitates UL555S test.

### 2. Reopenable Two Sensor Fire-Smoke Combination Damper

(Since this system involves the Firefighters' Smoke Control System, inform fire department.)

#### With FSCS switch in Auto position:

- a.  Disconnect power from smoke detector or relay contacts. *Actuator springs damper closed.*
- b.  Reconnect power. *Actuator drives damper open.*
- c.  Trip thermal sensor. *Actuator springs damper fully closed.*
- d.  Press manual reset. *Actuator drives damper open.*

#### Test FSCS switch functions:

- a.  Move FSCS switch to Off position. *Actuator springs damper fully closed.*
- b.  Move FSCS switch to Hand position. *Actuator drives damper open.*
- c.  Trip secondary (higher temperature) thermal sensor. *Actuator springs damper fully closed.*
- d.  Press manual reset of secondary sensor. *Actuator drives damper open.*

#### Move FSCS switch back to Auto position:

- a.  Actuator springs damper closed if Primary sensor is still open.
- b.  Actuator stays open if Primary sensor has re-closed.

**When completed, ensure sensors are reset and smoke detector is in normal state and FSCS switch is in Auto. Damper is normally Open; check sequence of operation.**

Damper Numbers or Location Identifying Numbers.....

Date.....-.....-.....

Contractor.....

Service Technician (Print).....

Service Technician (Signed).....

Phone Number (.....).....

Notes.....

.....

.....