



Ease of Installation.

Belimo Piping Packages



Discover the advantages
www.belimo.us

BELIMO[®]

Save time and money

Belimo Piping Packages are a streamlined method of piping HVAC terminal units reducing time, space, and labor required to make the connection from the distribution piping to the coil. Piping packages are custom factory assemblies, which include isolation for control valve and coil, pressure/temperature test ports for balancing, manual air vents, and strainer with integral drain options. These customizable assemblies dramatically simplifying the contractor's job by reducing connections to as few as four with less opportunity for errors.

Available configuration with the Energy Valve, EPIV, PIQCV, QCV, CCV, and standard zone valve assemblies offer solutions for a wide variety of hydronic applications. Belimo piping packages are backed with a 5-year warranty.*

FEATURES

- Eliminates numerous piping connections saving time and money
- Convenient access allows for easy commissioning providing optimal performance
- Each standard or customized solution comes bagged and tagged for easy job site distribution
- Factory assembled and 100% leak tested for reliable operation

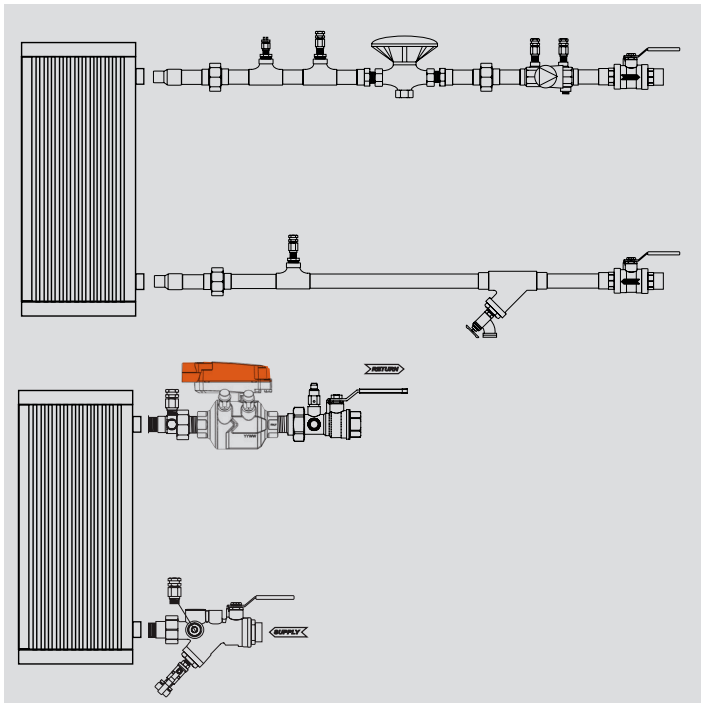

The Conventional Way

18 Pieces, 22 Connections
 10 minutes/connection x 22 connections
 220/60 minutes= 3.66 hours
3.66 hours x \$36 an hour= Labor Cost of \$132

The Belimo Way

2 Pieces, 4 Connections
 10 minutes/connection x 4 connections
 40/60 minutes= 0.667 hours
0.667 hours x \$36 an hour= Labor Cost of \$24

*2-year warranty on standard zone valves.

Piping packages at a glance

Use Belimo SelectPro™ the software tool for accurate sizing and selecting.

Standard Packages	Size	Union	Manual Balance Valve	Isolation Valve	Strainer	Hoses	5-Year Warranty
Energy Valve	½" - 2"	■		■	■	■	■
EPIV	½" - 2"	■		■	■	■	■
PIQCV	½" - ¾"	■		■	■	■	■
CCV	½" - 2"	■	■		■	■	■
QCV Zone Valve	½" - ¾"	■	■		■	■	■
Standard Zone Valve	½" - 1"	■	■		■	■	

Pressure Independent

2-way Electronic Pressure Independent Valve (EPIV) / Energy Valve (EV)

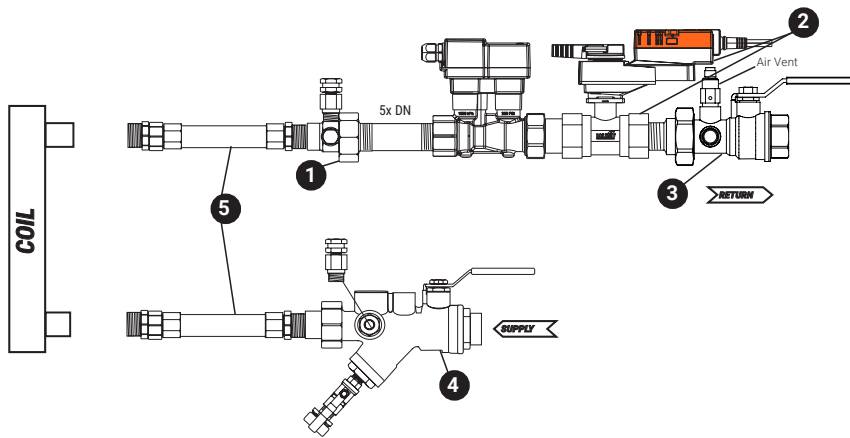

1. Union with 5x DN tail
2. Belimo valve assembly
3. Isolation valve
4. Strainer or isolation valve
5. Optional hoses are available

2-way Pressure Independent Quick Connect Valve (PIQCV)

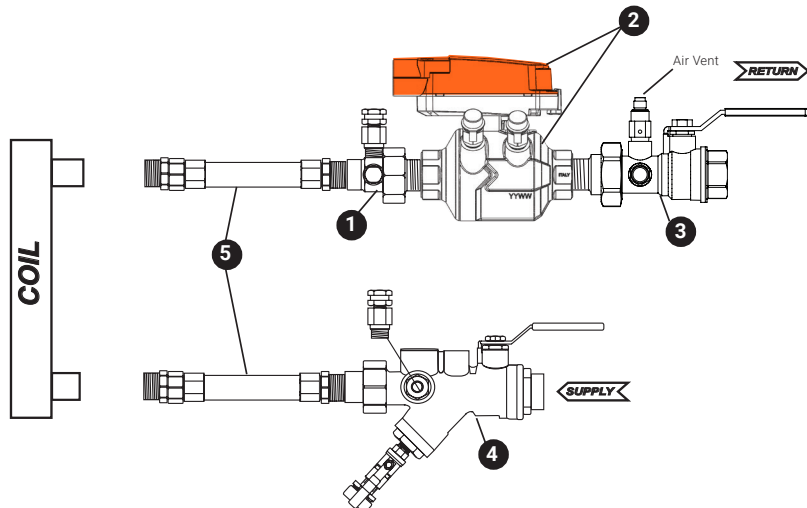

1. Union
2. Belimo valve assembly
3. Isolation valve
4. Strainer or isolation valve
5. Optional hoses are available

Factory assembled and tested

Pressure Dependent

2-way Characterized Control Valve (CCV)

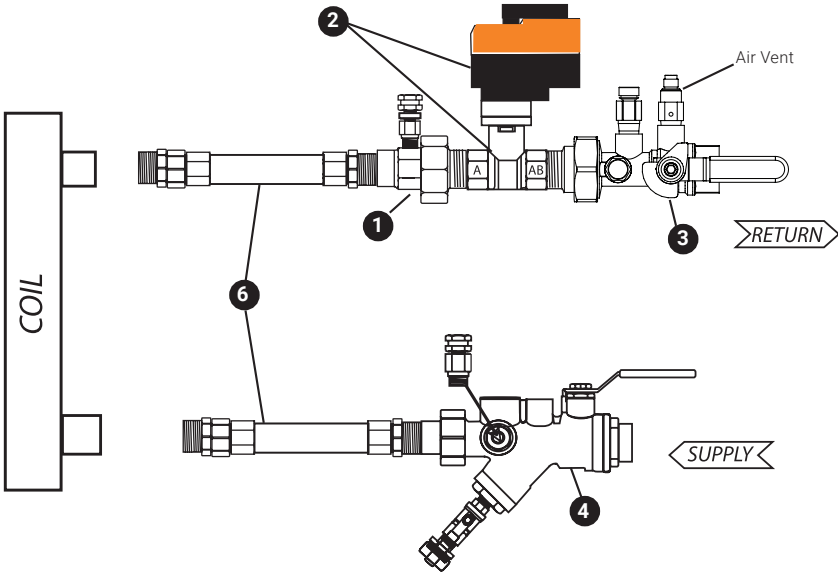

- 1. Union
- 2. Belimo valve assembly
- 3. Manual balance valve
- 4. Strainer or isolation valve
- 5. Isolation valve
- 6. Optional hoses are available

3-way Characterized Control Valve (CCV)

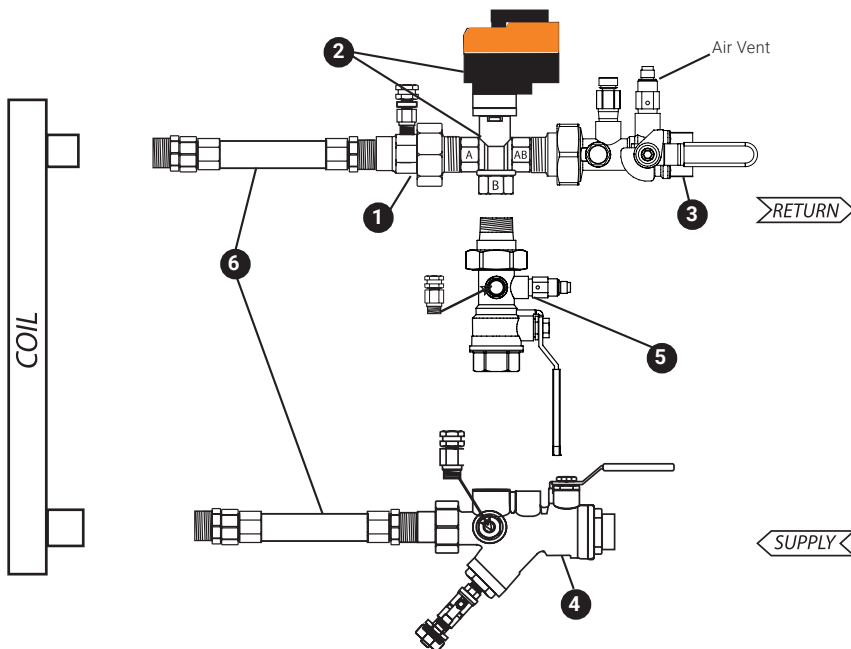

Pressure Dependent

2-way Belimo ZoneTight™ Zone Valve, Quick Connect Valve (QCV)

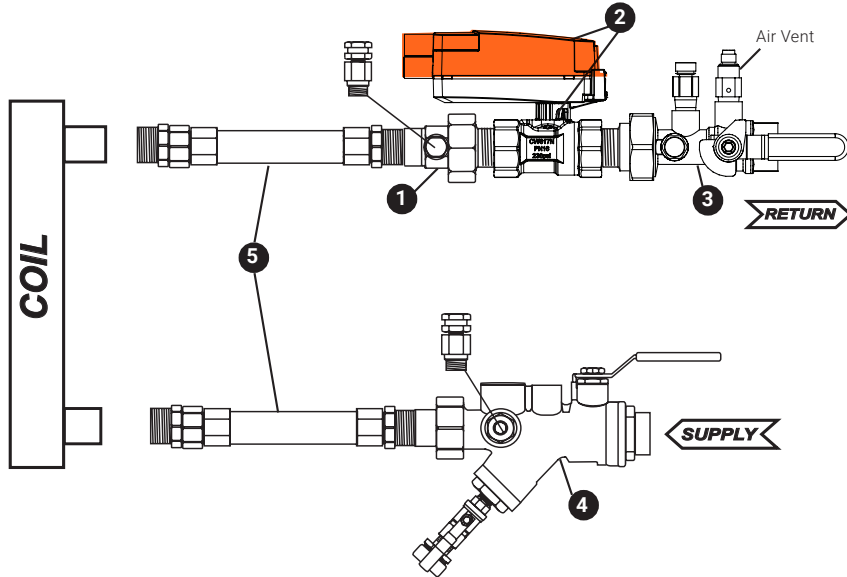

1. Union
2. Belimo valve assembly
3. Manual balance valve
4. Strainer or isolation valve
5. Optional hoses are available

2-way Standard Zone Valve

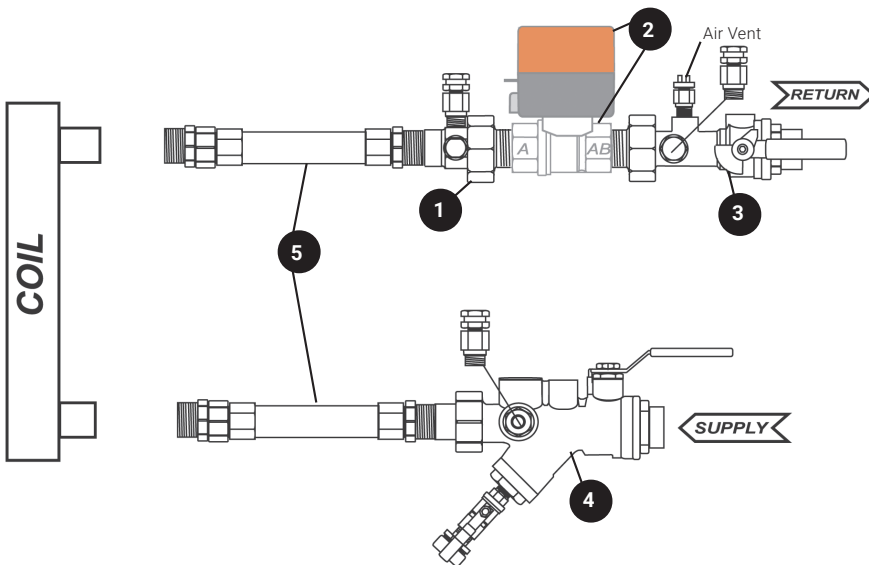

Featured components

Union combined with multiple fittings, and (pressure/temperature) PT readout port into a single part.

- ❶ ¼" PT readout port
- ❷ Forged brass body available in male NPT, female NPT, copper sweat or press-fit
- ❸ Tail piece available with up to two line size reductions, male NPT standard

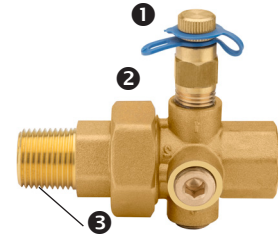

Isolation Valve combine with a union, manual air vent, and PT port into a single part which eliminates up to 7 piping connections.

- ❶ Manual air vent
- ❷ Forged brass body, chrome ball available in female NPT, copper sweat or press-fit
- ❸ ¼" PT readout port
- ❹ Triple seal, blow out proof stem with 2 Viton® o-rings and Teflon® packing with chrome ball
- ❺ Tail piece available with up to two line size reductions, male NPT standard

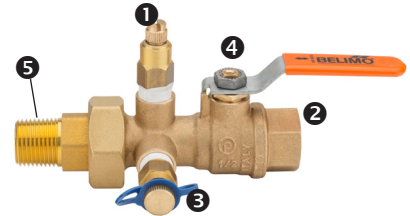

Manual Balance Valve is a combination of an isolation valve, union, manual air vent, PT readout port with a high signal, low loss venturi which eliminates up to 8 piping connections.

- ❶ Manual air vent
- ❷ Forged brass body available in female NPT, copper sweat or press-fit
- ❸ Forged brass memory stop with arc indicator pad
- ❹ Triple seal, blow out proof stem with 2 Viton® o-rings and Teflon® packing
- ❺ Tail piece available with up to two line size reductions, male NPT standard
- ❻ (2) ¼" PT readout ports

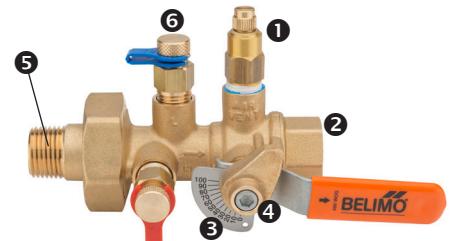

Strainer is a combination of an isolation valve, a 20 mesh stainless steel screen, union, and a PT port which eliminates up to 8 piping connections.

- ❶ Standard ¼" accessory tapping
- ❷ Forged brass body, chrome plated ball available in female NPT, copper sweat or press-fit
- ❸ Solid brass stem with 2 Viton® o-rings and Teflon® packing
- ❹ Large 20 mesh stainless steel screen
- ❺ ¼" PT readout port
- ❻ ¼" Ball valve drain with ¾" hose end connection with cap
- ❼ Tail piece available with up to two line size reductions, in male NPT, female NPT, and copper sweat

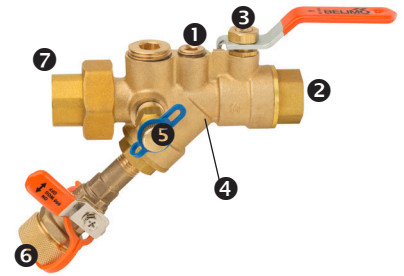

Hoses are designed for operating conditions in heating and air conditioning coil applications and are not sensitive to glycol or water treatment fluids. Hoses have a male NPT connection and are sold two per package. Available length options include 12, 18, 24, and 36 inches.



Note: Standard pipe packages are ½" to 1". Packages 1¼" to 2," or that include components with press-fit connections, extensions, or less P/T ports may carry increased lead time. Consult the factory.

Viton® is a register trademark of DuPont.

Exceptional service

For over 40 years, Belimo has successfully focused on the heating, ventilation, and air conditioning markets providing quality solutions that will increase energy efficiency and reduce installation costs with the fastest delivery times in the industry. Our innovative products have always been designed to help achieve objectives better, faster, and more economically. Investing in new technology is key to our success, and Belimo will continue to offer products to help businesses succeed.



5-year warranty



2-year warranty



Global support



Tested quality



On-time delivery



Extensive service



Complete product range

Belimo Americas

USA, Latin America, and the Caribbean: www.belimo.us

Canada: www.belimo.ca, Brazil: www.belimo.com.br

Belimo Worldwide: www.belimo.com

